



MAGIS PRO V2

Split single-phase inverter reversible air-water heat pumps with outdoor condensing unit and hydronic module



MAIN CONTENTS

1	MAGIS PRO 4 - 6 - 9 V2 FEATURES (MONO-PHASE)	5
2	AUDAX PRO V2 DIMENSIONS AND CONNECTIONS (CONDENSING UNIT)	6
3	MAGIS PRO V2 DIMENSIONS AND CONNECTIONS (HYDRONIC MODULE)	7
4	SINGLE AUDAX PRO V2 MINIMUM INSTALLATION DISTANCES	8
5	AUDAX PRO V2 MINIMUM INSTALLATION DISTANCES (SEVERAL APPLIANCES)	9
6	DRAIN HOLES AND CONDENSATE DRAIN	10
7	COOLING CIRCUIT FUNCTIONING LIMITS.....	11
8	INDOOR UNIT HYDRAULIC CIRCUIT COMPONENTS.....	12
9	INTEGRATED RESISTANCE KIT FOR SYSTEMS FROM 3 KW MAGIS PRO V2 (CODE 3.030991)	13
10	GRAPH OF INDOOR UNIT PUMP FLOW RATE/HEAD	14
11	HYDRAULIC DIAGRAM MAGIS PRO V2 (INDOOR UNIT)	15
12	AUDAX PRO V2 (EXTERNAL CONDENSING UNIT) HYDRAULIC DIAGRAM.....	16
13	ELECTRONIC MANAGEMENT FUNCTIONS MAGIS PRO V 2.....	17
14	ELECTRIC CONNECTION CABLES FEATURES.....	29
15	OUTDOOR UNIT TERMINAL BLOCK ELECTRICAL CONNECTIONS.....	30
16	INDOOR UNIT TERMINAL BLOCK ELECTRICAL CONNECTIONS	31
17	MAGIS PRO V2 P.C.B.	33
18	INSTALLING THE CHILLER LINES.....	37
19	PRODUCT FICHE (REGULATION 811/2013) MAGIS PRO 4 V2.....	39
20	"POWER" "COP" AND "EER" MAGIS PRO 4 V2	40
21	PRODUCT FICHE (REGULATION 811/2013) MAGIS PRO 6 V2.....	42
22	"POWER" "COP" AND "EER" MAGIS PRO 6 V2	43
23	PRODUCT FICHE (REGULATION 811/2013) MAGIS PRO 9 V2.....	45
24	"POWER" "COP" AND "EER" MAGIS PRO 9 V2	4
25	TECHNICAL DATA MAGIS PRO V2.....	48
26	KIT 2 ZONES FOR COUPLING MAGIS PRO V2 (CODE 3.026301)	50
27	SYSTEM MANAGER.....	56
28	REMOTE PANEL OF ZONE (WITH SYSTEM MANAGER).....	58
29	REMOTE CONTROL OF ZONE (WITH SYSTEM MANAGER).....	58
30	TEMPERATURE/HUMIDITY SENSOR (WITH SYSTEM MANAGER)	58
31	EXPANSION BOARD FOR ZONE MANAGEMENT (WITH SYSTEM MANAGER).....	58
32	DISTRIBUTION KIT TO THE SYSTEM (WITH SYSTEM MANAGER)	59
33	DEHUMIDIFIER.....	63
34	INTRODUCTION WITH COMMENTARY TO THE DIAGRAMS: MAIN APPLICATIONS.....	67
35	HYDRAULIC DIAGRAM: MAGIS PRO V2 + KIT 2 ZONES (1 DIRECT AND 1 MIXED) + INTEGRATIVE RESISTANCE FOR HEAT SYSTEM	68
36	HYDRAULIC DIAGRAM: MAGIS PRO V2 (AIR CONDITIONING ONLY) + BOILER PLUS + SYSTEM DISTRIBUTION KIT + SOLAR HEATING FOR DHW + SYSTEM MANAGER	70
37	OPTIONAL FOR DIRECT COUPLING TO MAGIS PRO V2 (STAND ALONE)	72
38	OPTIONAL IN THE PRESENCE OF SYSTEM MANAGER	73
39	TRIO V2 WITH SYSTEM PRO (MAGIS PRO V2 + POSSIBLE RESISTANCES) IN SOLAR / DOMUS CONTAINER.....	75
40	BASIC MAGIS PRO WITH MAGIS PRO V2 IN SOLAR / DOMUS CONTAINER.....	79
41	SUPER TRIO WITH MAGIS PRO V2 IN SOLAR / DOMUS CONTAINER FOR SUPER TRIO	83

MAGIS PRO V2



Range of "split" inverter reversible air/water heat pumps, composed of an outdoor condensing unit and an indoor hydronic module; a single "pack" code identifies the complete system (hydronic module + condensing unit). There are 3 versions (MAGIS PRO 4 V2, MAGIS PRO 6 V2, MAGIS PRO 9 V2), all with single-phase supply voltage. The water circuit is fully protected against freezing because installed inside the home (in this case there is no need to add antifreeze); it is, therefore, particularly suitable for cold climate areas.

The MAGIS PRO V2 versions are ideal for conditioning rooms in central heating mode (maximum flow temperature 65°C) in cooling mode, and can produce DHW coupled with a separate storage tank unit.

Make the refrigerant connections between the hydronic module and the outdoor condensing unit coolant gas R32).

At plant application level, the system can be combined to electric resistances/boiler; for the production of DHW, MAGIS PRO V2 is equipped with standard integrated motorised 3-way valve (connection to a storage tank).

The System manager is available as optional, to be used mainly when having to combine an integrative boiler: it is capable of identifying the most economical energy source at a given time and therefore choose the right appliance to activate.

The hydronic module of the MAGIS PRO V2 is approved for outdoor use in a partially protected area and can also be installed inside the SOLAR CONTAINER or the DOMUS CONTAINER, in TRIO V2 (PRO System) or BASIC MAGIS PRO applications, or inside the CONTAINER for SUPER TRIO or the DOMUS CONTAINER for SUPER TRIO (in all solutions you can choose between 4, 6 or 9 kW power). MAGIS PRO V2 also meets the requirements of the ErP Directive (2009/125/EC) and ELD (2010/30/EC); there are a number of optional kits available, which allow it to be used in different plant applications.



MAGIS PRO V2

1 MAGIS PRO 4 - 6 - 9 V2 FEATURES (MONO-PHASE)

"Split" inverter reversible air/water heat pumps, composed of an outdoor condensing unit and an indoor hydronic module; a single code identifies the complete system.

Main components:

- **Outdoor condensing unit** (AUDAX PRO V2) which mainly includes rotary compressor, inverter electronics, throttle valve, 4-way valve for cycle inversion, finned exchange coil with outdoor air (with single fan). The cooling circuit is already preloaded in the condensing unit (refrigerant R32); it is equipped with shut-off valves for the R32 circuit;
- **Wall-hung hydronic module**, shape and appearance similar to a boiler, which includes the hydraulic circuit components for connection to the system, as well as the management electronics and of communication with the condensing unit; in particular, it is composed of a 72 plate R32/water heat exchanger, 12 litre system expansion vessel, water manifold, flow meter, hydraulic unit with low power 7 m c.a. pump, 3-way motorised diverter valve (for coupling with separate storage tank), transformer for managing internal communication board with outdoor condensing unit, management electronics;
- Hydraulically the module is set-up for connection to a heating/cooling zone and for connection to the DHW storage tank; there are also the R32 connections for the condensing unit;
- Within the hydronic module you can place the integrative electric resistance kit for 3 kW system (optional, directly controlled by the electronics of the hydraulic module), to supplement the operation in cases where a gas boiler is not combined;
- Compared with block heat pumps, the water circuit is fully protected against freezing because it can be installed inside the home (important in cold zones);
- Max. flow water temperature 65 °C (for central heating systems with low and medium temperatures);
- The electronics of MAGIS PRO V2 is designed to directly manage 3 zones (one direct and two mixed), for the third mixed zone it is necessary to provide the configurable relay interface kit code 3.015350) for both central heating and cooling operation; in this case MAGIS PRO V2 can be connected to remote zone panels via Bus connections (up to 3 can be provided), or it can be connected with simple on/off contacts (e.g. CHRONO 7) to control the room temperature of the 3 zones. 3 humidistats or 3 Modbus temperature and humidity sensors can be connected to control humidity;
- Possibility of setting 3 climatic curves for hot and 3 climatic curves for cold (for the 3 zones), on the electronics of the hydronic module, no need to provide for the system manager;
- Possibility to set on each zone if the zone is only hot, hot/cold, only cold (dehumidification included, with dew point calculation);
- The consent for the activation of the system and DHW resistances (both optional) is provided by MAGIS PRO V2 electronics (the power supply is to be taken separately);

- To manage the dehumidifiers, it is necessary to insert in the indoor wall-hung unit a 2 relay board kit (optional), to control 2 dehumidifiers (the third one is controlled by the configurable relay interface kit code 3.015350); the kit allows the dehumidifiers to be activated through a potential-free contact;
- The MAGIS PRO V2 electronics manages the anti-legionella function, which can only be activated if the system is provided with an auxiliary generator (resistance);
- Input to force activation with photovoltaic system that produces electricity;
- It includes a 230 V output to control summer/winter diverter valves in heating systems with fan coil cold/radiant panels; switching occurs with the change of mode (summer/winter) from the control panel;
- Possibility of connection to the System manager (optional), to be used mainly when wanting to combine an integrative boiler;
- The integrated electronics also manage the screed heating function in order to perform the initial central heating cycle on new radiant panel systems;
- System minimum water content for all 30 litre/kW models, for any type of system (minimum water content is mainly important to provide proper execution of defrosting cycles).

It is available in the model:

- | | |
|-------------------------|----------------------|
| • MAGIS PRO 4 V2 | code 3.030606 |
| • MAGIS PRO 6 V2 | code 3.030607 |
| • MAGIS PRO 9 V2 | code 3.030608 |

EC Declaration Of Conformity.

2 AUDAX PRO V2 DIMENSIONS AND CONNECTIONS (CONDENSING UNIT)

AUDAX PRO 4 / 6 V2

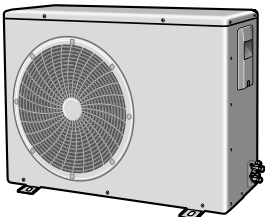
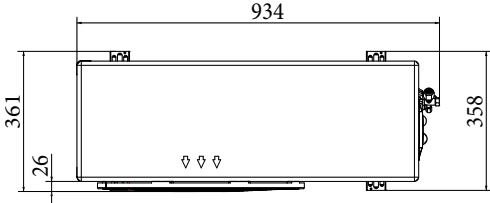
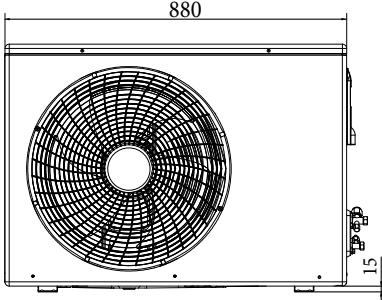
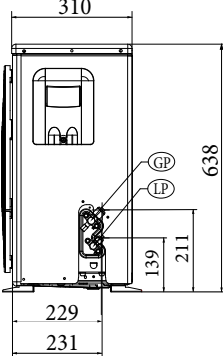
Height = 638 mm	Width = 880 mm	Depth = 364 mm	Condensate drain = Ø 20 mm
------------------------	-----------------------	-----------------------	-----------------------------------

	R32	
Model	LP (Cooling liquid)	GP (Gaseous liquid)
AUDAX PRO 4/6 V2	1/4" (6.35 mm)	5/8" (15.88 mm)

AUDAX PRO 9 V2

Height = 1010 mm	Width = 940 mm	Depth = 384 mm	Condensate drain = Ø 20 mm
-------------------------	-----------------------	-----------------------	-----------------------------------

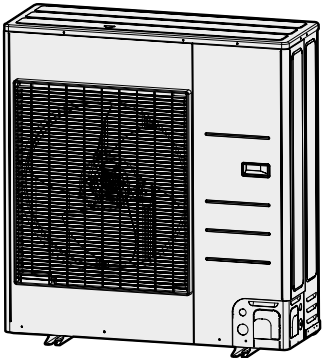
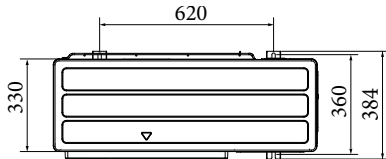
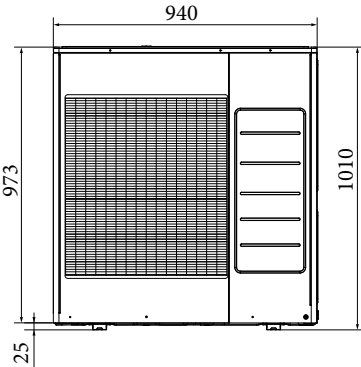
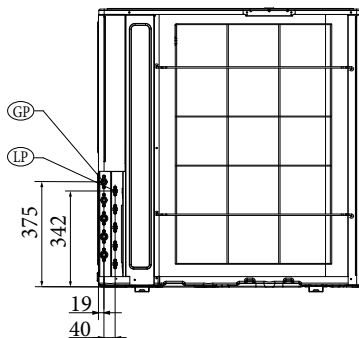
	R32	
Model	LP (Cooling liquid)	GP (Gaseous liquid)
AUDAX PRO 9 V2	1/4" (6.35 mm)	5/8" (15.88 mm)

MAGIS PRO V2

3 MAGIS PRO V2 DIMENSIONS AND CONNECTIONS (HYDRONIC MODULE)

Height = 760 mm	Width = 440 mm	Depth = 250 mm
-----------------	----------------	----------------

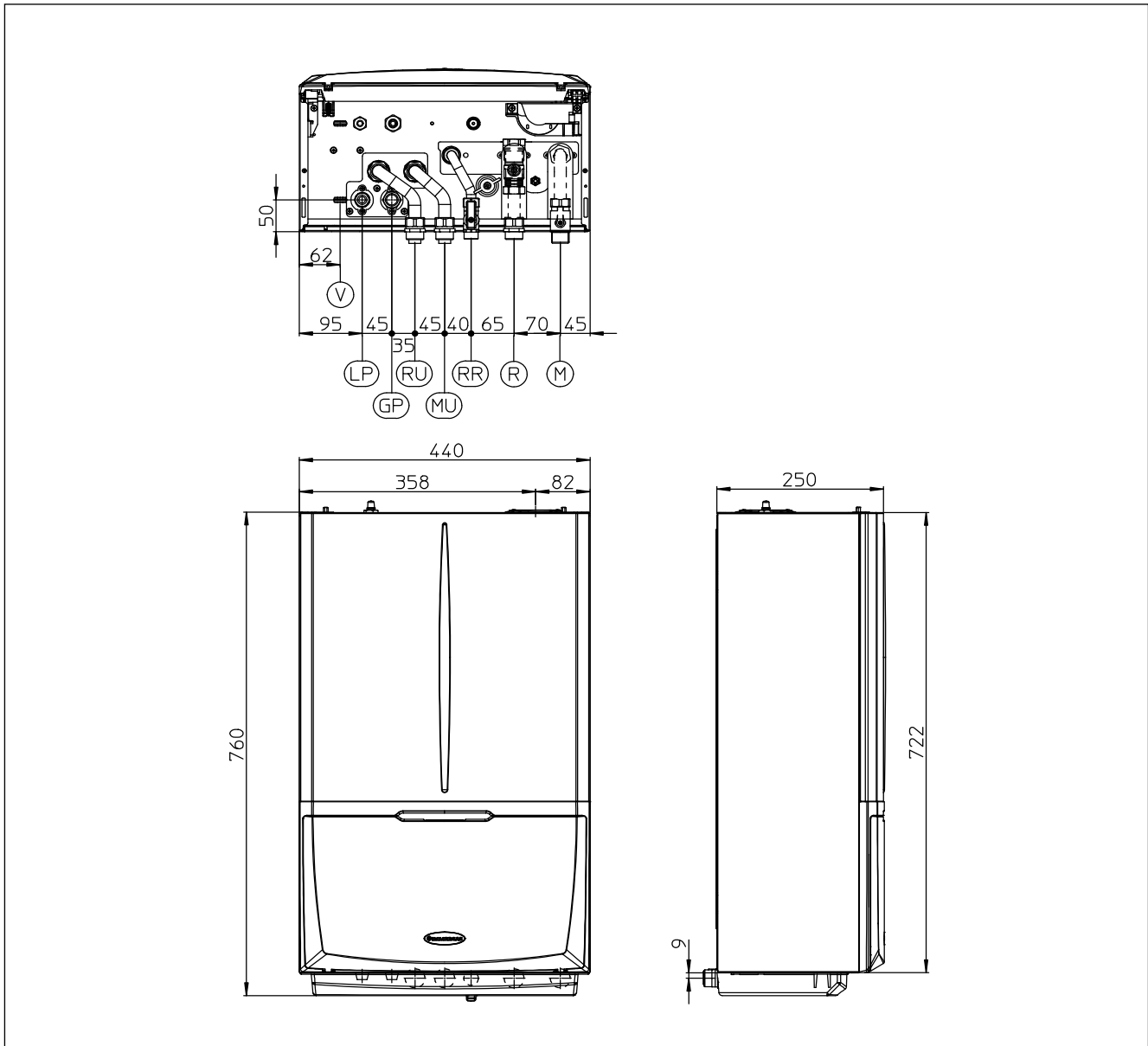

MAGIS PRO V2

Flow System	Return system	Flow Storage tank	Return Storage tank	Filling system	R32 LP	R32 GP	Expansion vessel Litres
M 3/4"	R 3/4"	MU 3/4"	RU 3/4"	RR 1/2"	1/4" (6.35 mm)	5/8" (15.88 mm)	12 (real 11.7)

4 SINGLE AUDAX PRO V2 MINIMUM INSTALLATION DISTANCES

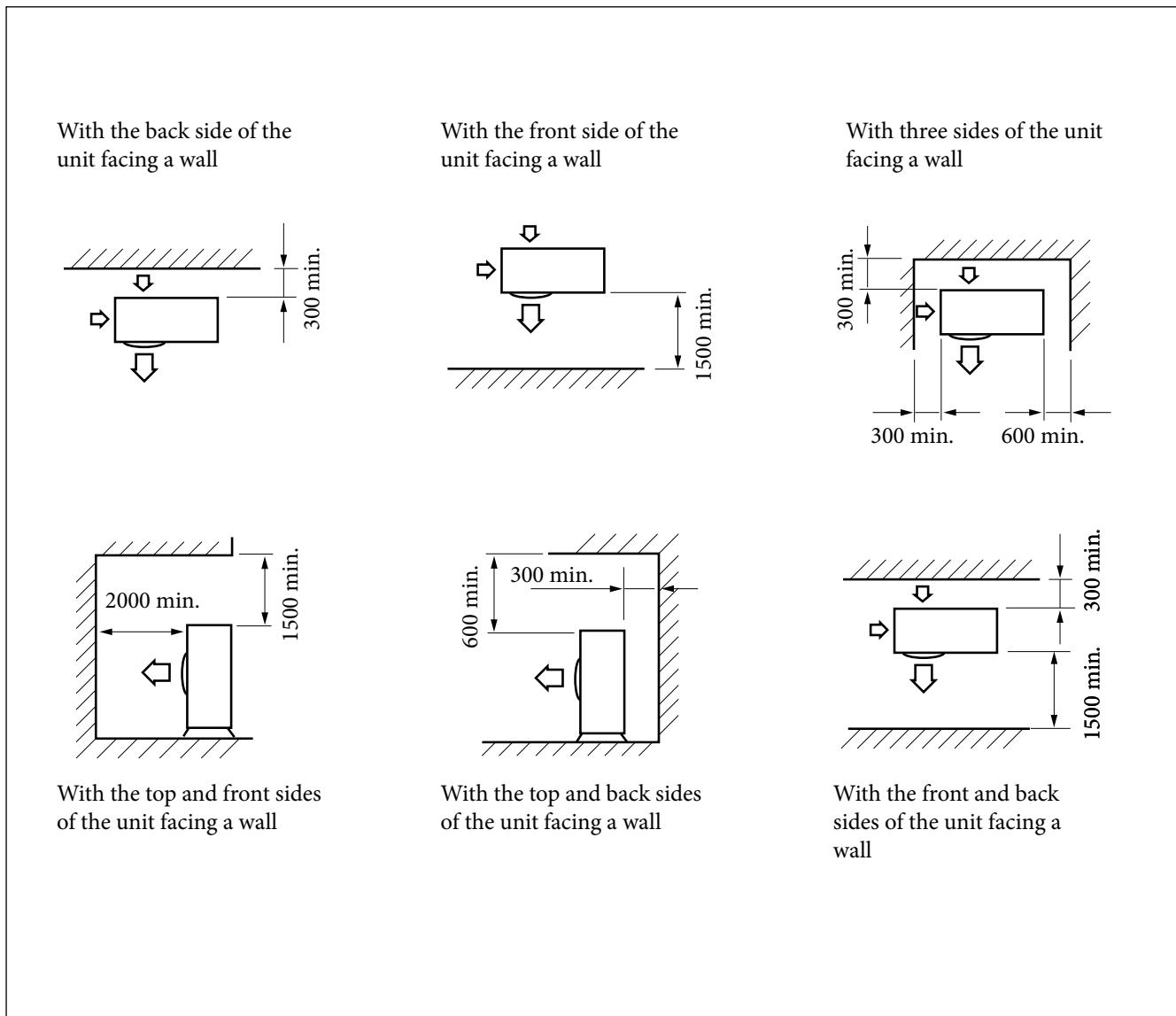

Place of installation:

The place of installation is very important and must be established by the system's designer or by a specifically qualified person, and must consider the technical requirements, standards and laws in force.

- The condensing unit must be installed outside the building only; the indoor unit must be installed inside the building or outdoors in a partially protected place.
- It is recommended to avoid:
 - positioning in basement windows;
 - obstacles or barriers that cause recirculation of exhaust air;
 - places with aggressive atmospheres;
 - limited spaces or anyhow in places where sound levels from the appliance can be enhanced through reverberations or resonance;
 - positioning in corners where there is an accumulation of dust, leaves and anything else that can reduce the appliance's efficiency due to blocked passageways;

- prevent exhaust air from the device from coming into the rooms through doors or windows, thus disturbing people;
- The appliances must:
 - be placed on a level surface that is able to withstand its weight;
 - be placed on a slab that is hard enough and which does not transfer any vibrations to the underlying or adjacent rooms;
 - installed by means of the vibration-dampening supports supplied with the machine.
- If the unit is installed in zones subject to heavy snow, it will be necessary to raise the machine by at least the height of the strongest expected snowfall or, alternatively, use wall-support brackets (optional).

MAGIS PRO V2

5 AUDAX PRO V2 MINIMUM INSTALLATION DISTANCES (SEVERAL APPLIANCES)

The front side of the unit facing a wall

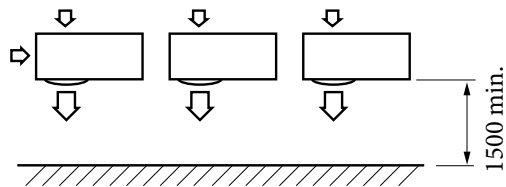

With three sides of the units facing a wall

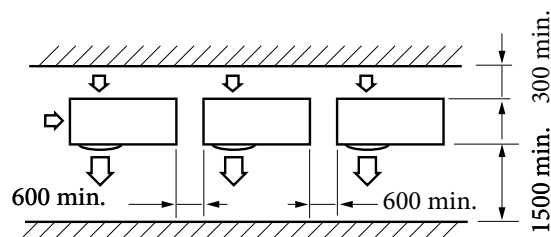
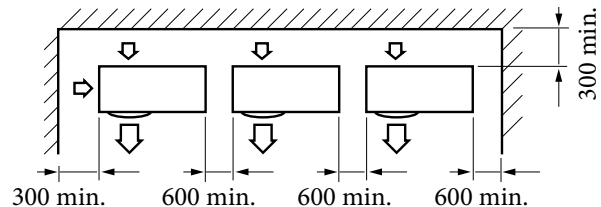

With the front and back sides of the units facing a wall

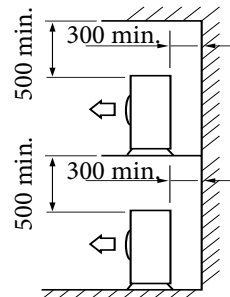

With the top and back sides of the units facing a wall

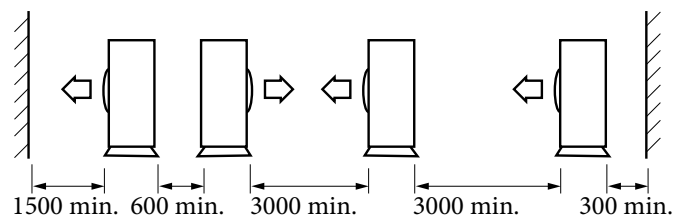

With the units facing each other and with the front and back sides of the end units facing a wall

In addition:

- the unit must be installed in a position protected from snow falling from above. If this is not possible, you must at least prevent the snow from clogging the air/coolant exchanger (even by constructing a small protective roof for the unit, if necessary);
- the effects of the wind can be minimised by installing the unit with the intake side facing a wall;
- the unit must not be installed with the intake side against the wind;
- the effects of the wind can be further minimised by installed a deflector plate facing the unit air flow side (not supplied).

N.B.: The spaces shown must be left free to allow air to circulate and to ensure accessibility for repairs or maintenance on every side of the units. In fact, it must be possible to disassemble all the unit components under the utmost safety conditions (both for objects and for people).

6

DRAIN HOLES AND CONDENSATE DRAIN

If the produced condensate is drained through the drain pipe, connect the standard supplied drain fitting (1) in one of the drainage holes on the bottom of the appliance and close the other holes with drain plugs (see drawings below) and use the drain pipe (16 mm internal diameter) commercially available so that it conveys the water to the desired location. In the event of installation in very cold zones or zones subject to heavy snow where the condensate drain pipe can freeze, take the necessary precautions to keep the drainage holes or the condensate drain pipe free.

N.B.: If the water produced by the unit is not properly drained, the performance of the entire system will suffer a negative impact and the system itself could be damaged.

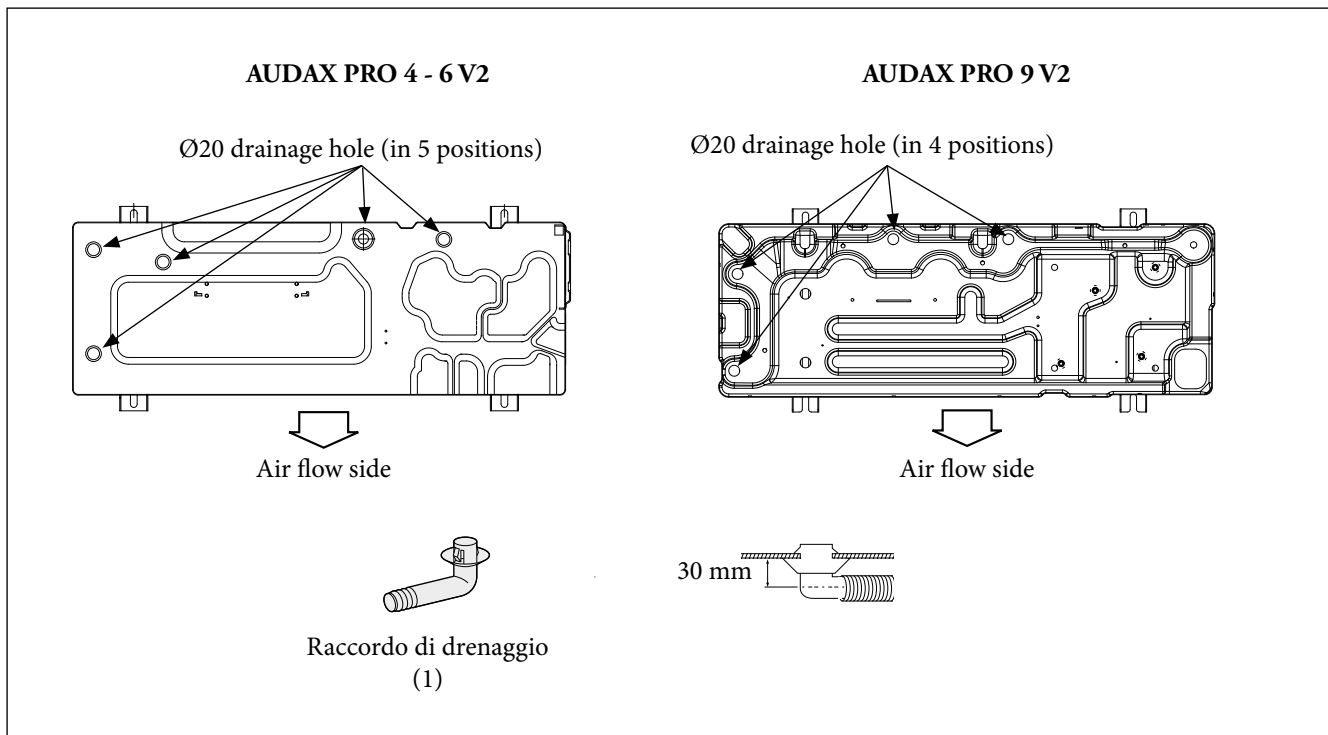

MAGIS PRO V2

7 COOLING CIRCUIT FUNCTIONING LIMITS

Central heating

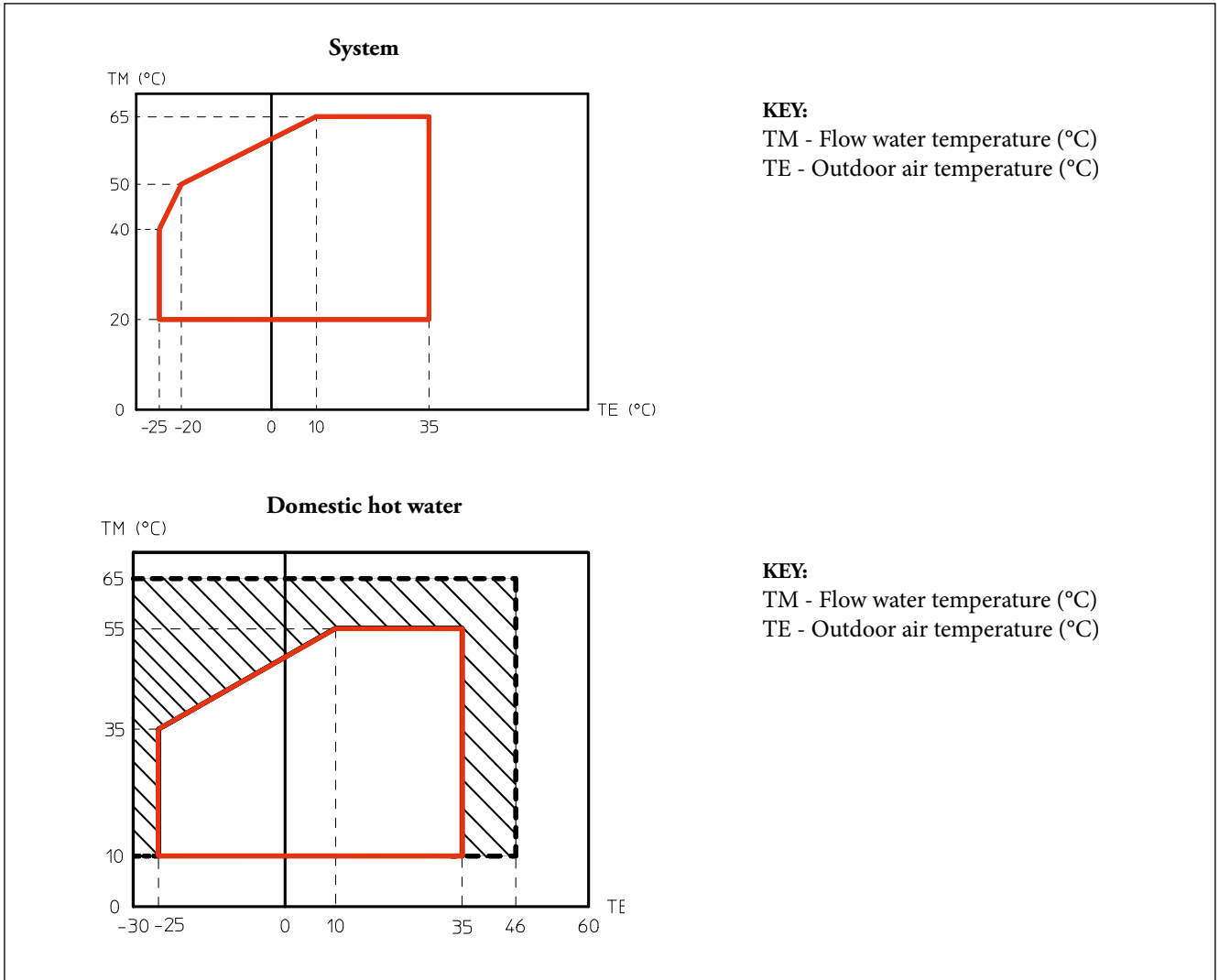

Cooling

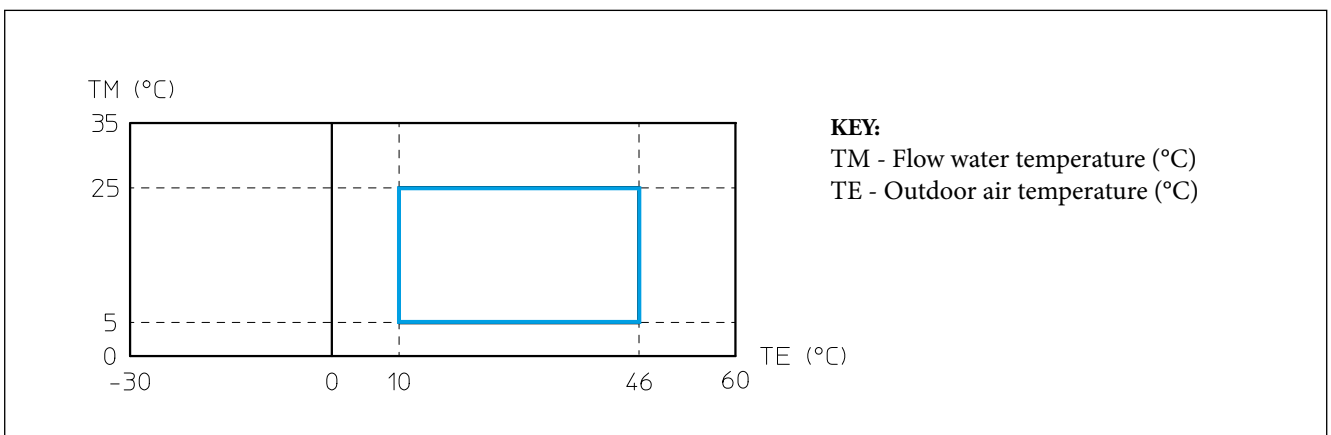

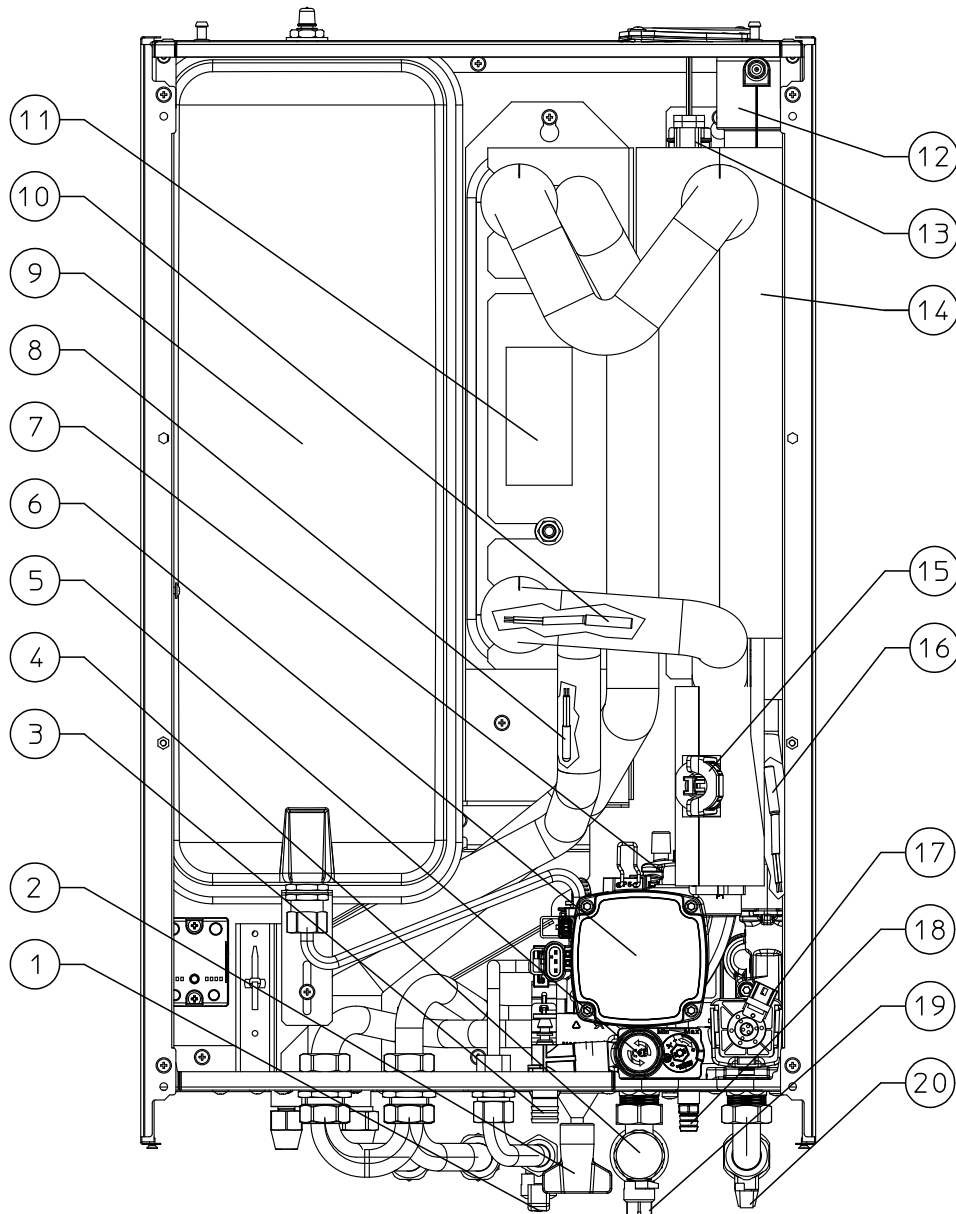

KEY:

- | | |
|---|---|
| 1 - Domestic hot water inlet cock for filling | 12 - Air vent valve |
| 2 - System filling valve | 13 - Heating system integrated electrical resistance cap (optional) |
| 3 - 3-bar safety valve drain fitting | 14 - Central heating manifold |
| 4 - Filter that can be inspected | 15 - System flow-meter |
| 5 - 3 bar safety valve | 16 - Return probe |
| 6 - Hydronic unit circulator | 17 - 3-way valve (motorised) |
| 7 - Air vent valve | 18 - System draining valve |
| 8 - Liquid phase detection probe | 19 - System shut-off cock |
| 9 - System expansion vessel | 20 - System shut-off cock |
| 10 - Flow probe | |
| 11 - Plate heat exchanger | |

MAGIS PRO V2

9 INTEGRATED RESISTANCE KIT FOR SYSTEMS FROM 3 kW MAGIS PRO V2 (CODE 3.030991)

KEY:

- 1 - 3 kW Electric resistance
- 1A - O.R. seal
- 2 - Plug fastening screws
- 3 - Cap
- 4 - Gasket
- 5 - Resistance housing closing plug

TECHNICAL DATA

Electric power supply	230V-50Hz single phase+earthing
Absorption	3 kW
Working temperature	55 °C
Maximum temperature	75 °C

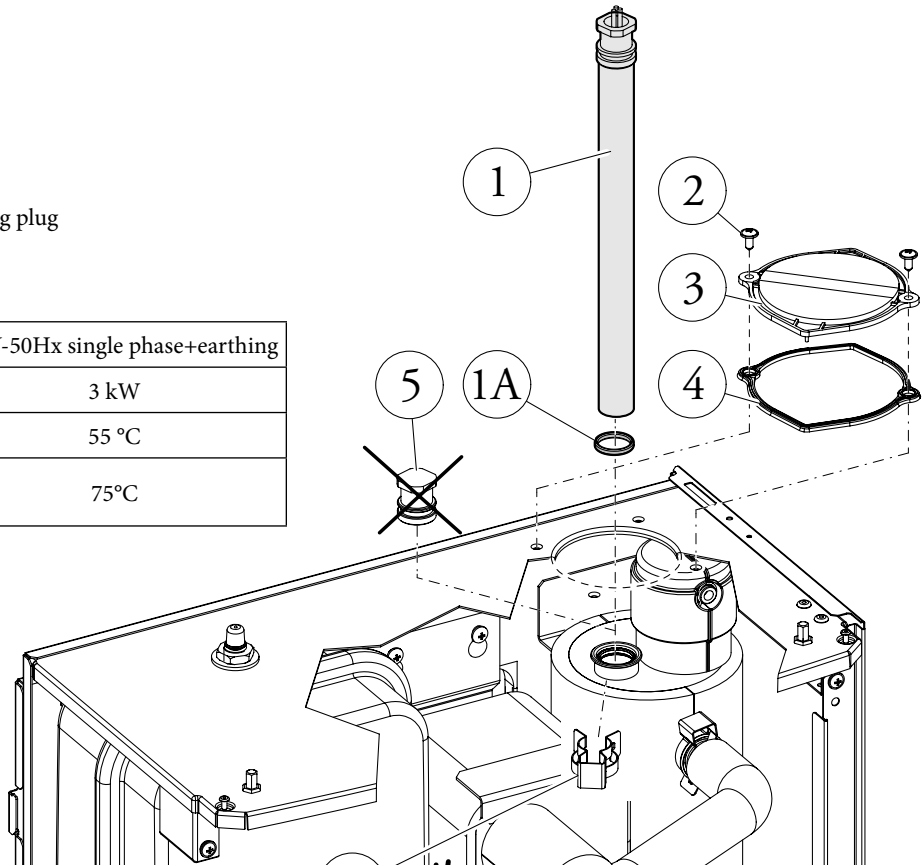

Colour code key:

- BL - Blue
- BR - Brown
- G - Green
- GY - Grey

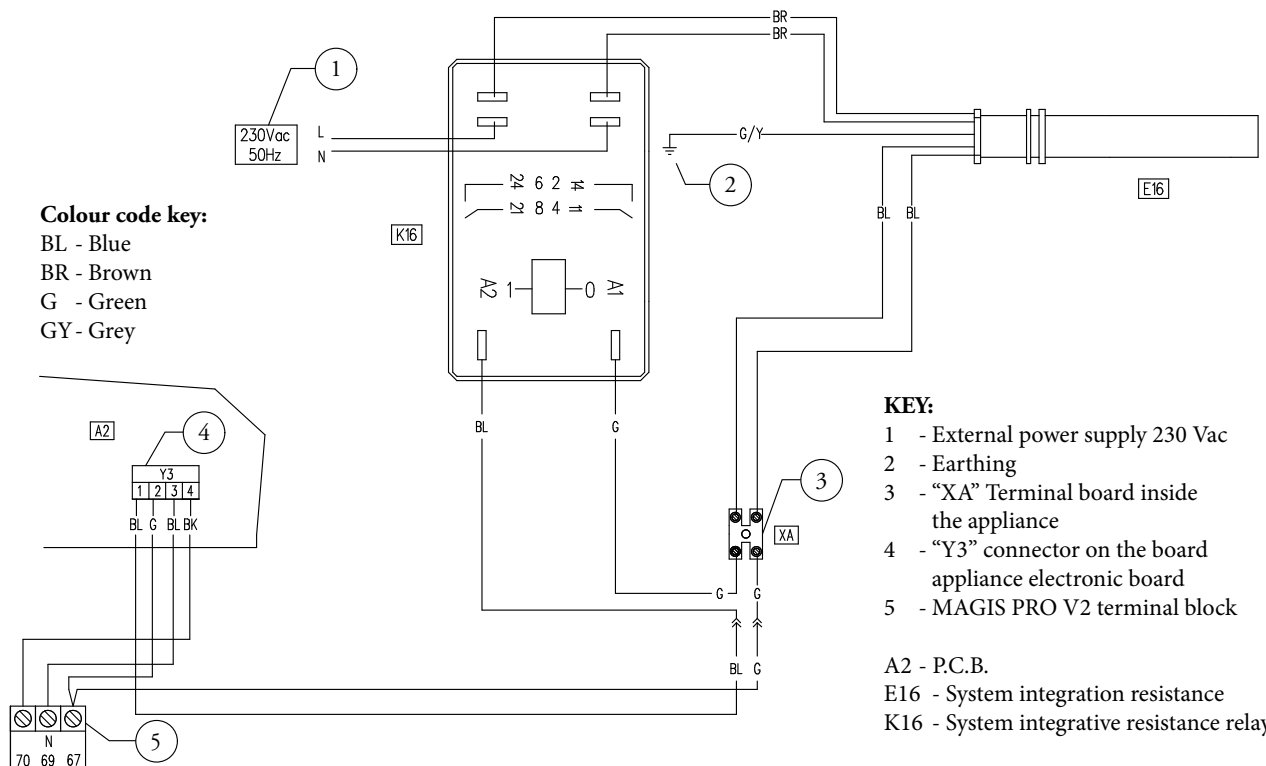

KEY:

- 1 - External power supply 230 Vac
- 2 - Earthing
- 3 - "XA" Terminal board inside the appliance
- 4 - "Y3" connector on the board appliance electronic board
- 5 - MAGIS PRO V2 terminal block

A2 - P.C.B.

E16 - System integration resistance

K16 - System integrative resistance relay

10 GRAPH OF INDOOR UNIT PUMP FLOW RATE/HEAD

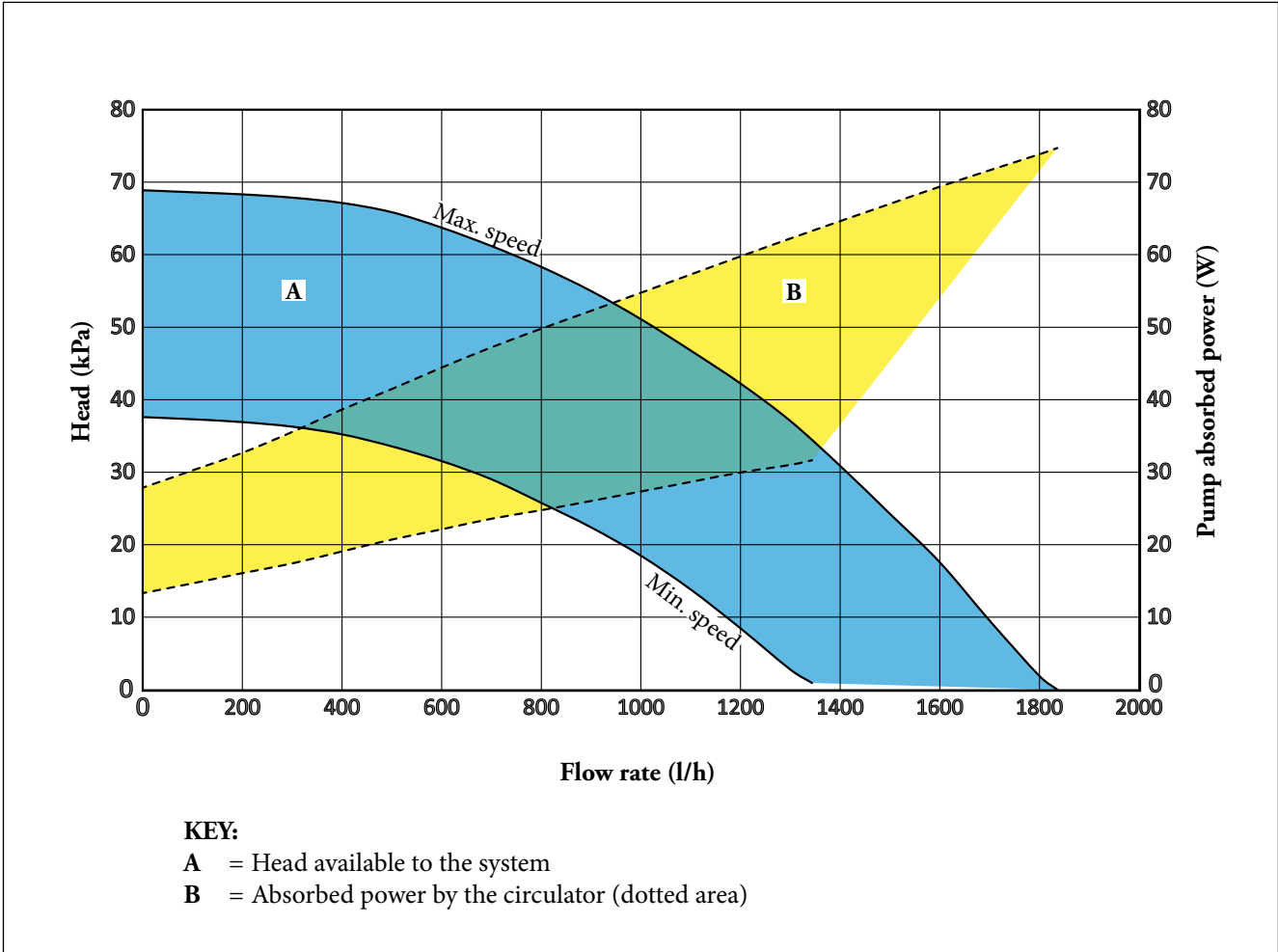

10.1 INDOOR UNIT PUMP SETTINGS AND CONFIGURATIONS

The hydronic modules are supplied with a low power consumption pump with variable speed control. The pump speed is set via parameter "A04" (which can be set between 55% and 100%). The minimum speed set via the "A03" parameter is used for special functions (e.g. pump anti-locking function). **NOTE: for proper system operation, make sure that the minimum flow rate in operating conditions never drops below 500 l/h.**

Treating the feed water allows you to prevent problems and maintain the function and efficiency of the generator over time. Legislative Decree 26/06/2015 requires a chemical treatment of the thermal system water, in compliance with the UNI 8065 standard, in the cases provided for by the Decree.

TECHNICAL NOTE: System minimum water content:
 To facilitate proper execution of the heat pump defrost cycles, a minimum water content in the system is required, which must be **30 litres** for all kinds of system. So attention must be paid to the systems divided over several zones, where the water content available to the machine changes continuously. This is why it may be necessary to provide a heating flywheel that guarantees normal operation with systems divided into zones (with variable water content in circulation). This minimum content also guarantees proper operation with fan coils used for cooling (a condition in which the flow temperature is very low and has significant heat load variations that vary the number of active fan coils). It is also important to check that the dehumidifier line has a minimum of **3 U/kW** of the machine (dehumidifier hydraulic circuit connection).

MAGIS PRO V2

11

HYDRAULIC DIAGRAM MAGIS PRO V2 (INDOOR UNIT)

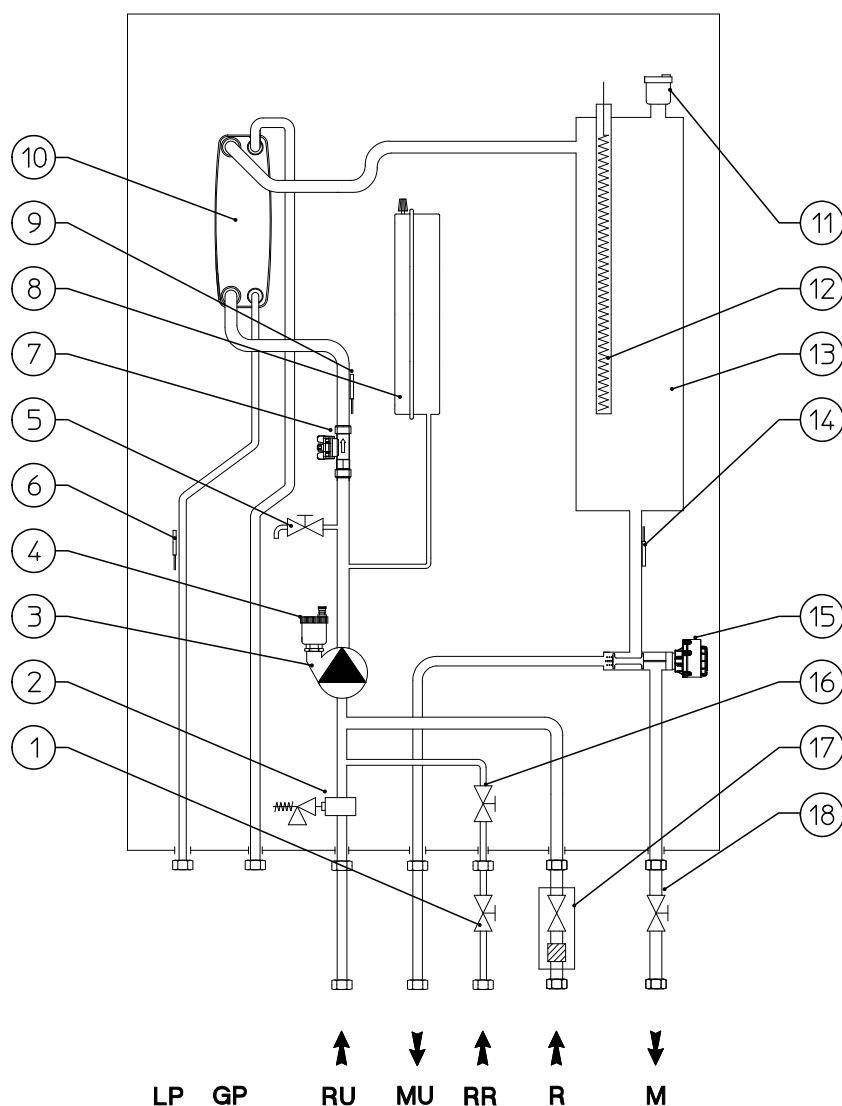

KEY:

- | | |
|--|---|
| 1 - Domestic hot water inlet cock for filling | 14 - Flow probe |
| 2 - 3 bar safety valve | 15 - 3-way valve (motorised) |
| 3 - Hydronic unit circulator | 16 - System filling valve |
| 4 - Air vent valve | 17 - System with inspectable filter cut-off fitting |
| 5 - System draining valve | 18 - System shut-off cock |
| 6 - Liquid phase detection probe | |
| 7 - System flow-meter | LP - Chiller line - liquid phase |
| 8 - System expansion vessel | GP - Chiller line - gaseous phase |
| 9 - Return probe | RU - Storage tank unit return |
| 10 - Plate heat exchanger | MU - Storage tank unit flow |
| 11 - Air vent valve | RR - System filling |
| 12 - Central heating integrated electric resistance (optional) | R - System return |
| 13 - Central heating manifold | M - System flow |

12 AUDAX PRO V2 (EXTERNAL CONDENSING UNIT) HYDRAULIC DIAGRAM

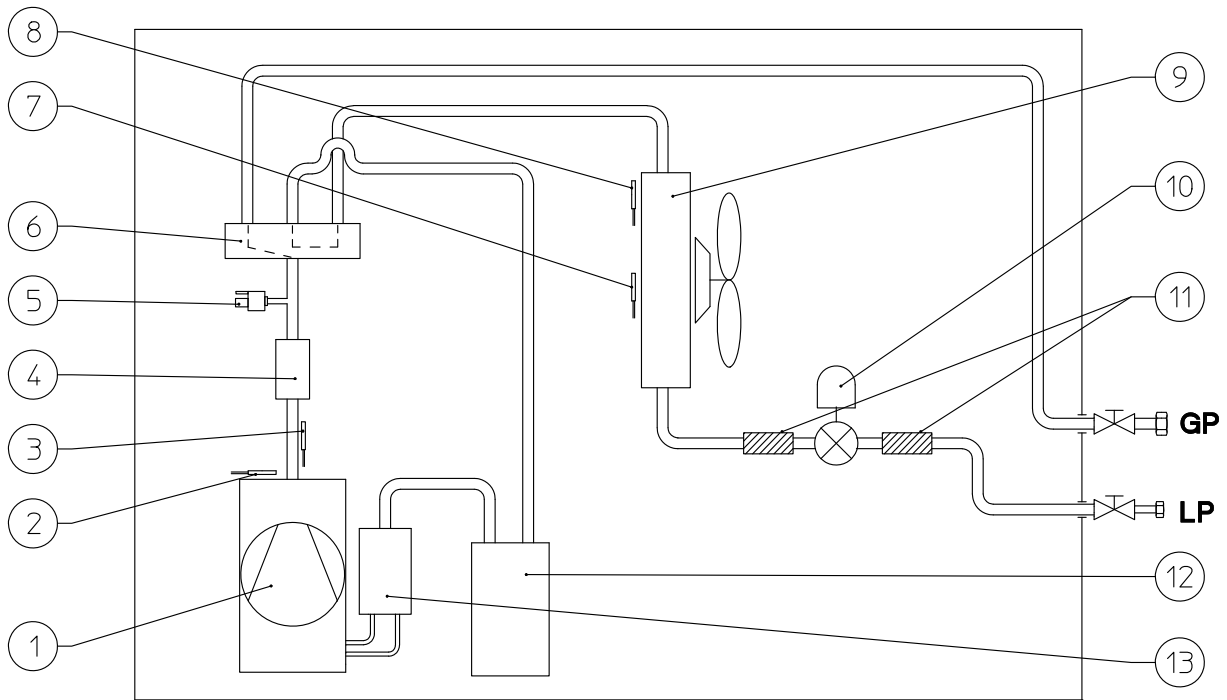

KEY:

- 1 - Compressor
- 2 - Compressor temperature
- 3 - Compressor outlet temperature
- 4 - Silencer
- 5 - High pressure switch
- 6 - 4-way valve
- 7 - Temperature of fluid in finned coil
- 8 - External probe/installation room temperature
- 9 - Finned coil + fan
- 10 - Electronic expansion valve
- 11 - Dryer filter
- 12 - Liquid receiver
- 13 - Liquid separator

LP - Chiller line - liquid phase
 GP - Chiller line - gaseous phase

MAGIS PRO V2

13

ELECTRONIC MANAGEMENT FUNCTIONS MAGIS PRO V2



The electronic of MAGIS PRO V2 is characterised by an integrated intelligent management system that establishes the system operating priority, on the basis of the external climatic conditions and central heating system flow temperature set.

It allows activating the electric resistances for both the heating system and for the DHW (both optional - power supply to be taken separately); the logic plans to activate the resistances if I do not reach the temperature set within the max. time (set a max. time for the system and a separate for the DHW), or below a certain outdoor temperature (also settable) I can immediately activate the electric resistance.

MAGIS PRO V2 works at sliding temperature, using the external probe present on the condensing unit (placed outside); it is prepared to directly manage 3 zones (one direct and two mixed, for the third mixed zone it is necessary to provide the configurable relay interface kit code 3.015350) for operation in both heating and cooling, with the possibility of setting 3 curves in hot and 3 curves in cold (for the 3 zones) without the need to provide the System manager. in this case MAGIS PRO V2 can be connected to remote zone panels (code 3.030863) via Bus connections (up to 3 can be provided), or it can be connected with simple on/off contacts (e.g. CHRONO 7) to control the room temperature of the 3 zones.

3 humidistats (code 3.023302) or 3 Modbus temperature and humidity sensors (code 3.030992) can be connected to control humidity.

When using the ModBus temperature and humidity sensor kit (code 3.030992), in order to make temperature requests it is necessary to match a room thermostat in the zone as it is not possible to set the room set directly from the control panel.

To manage the dehumidifiers, it is necessary to insert in the indoor wall-hung unit a 2 relay board kit (optional), to control 2 dehumidifiers (the third one is controlled by the configurable relay interface kit code 3.015350); the kit allows the dehumid-

ifiers to be activated through a potential-free contact.

For each zone, from the MAGIS PRO V2 electronics it is possible to set if the zone is only hot, hot/cold, only cold (dehumidification included, with dew point calculation).

There is an input for system activation in correspondence of electricity production by the photovoltaic system (if installed). This input (when active) forces the heating of a storage tank for the production of DHW at maximum temperature, to then meet any system demands.

It includes a 230 V output to control summer/winter diverter valves in heating systems with fan coil cold/radiant panels; switching occurs with the change of mode (summer/winter) from the control panel or from the remote panel of the zone.

The MAGIS PRO V2 electronics also manages the anti-legionella function, which can only be activated if the system is provided with an auxiliary generator (electric resistance).

The electronics of MAGIS PRO V2, in combination with the configurable relay interface kit (code 3.015350), also manages the activation of the recirculation pump.

In the presence of any "Puffer" which is heated by another energy source (e.g. thermal chimney), it is possible to connect the hydronic module with a temperature control probe (code 3.019375), exceeded the set temperature MAGIS PRO V2 remains off, but the system zones can continue to operate (obviously in the presence of requests).

Whereas, to control a possible solar system, a solar control unit is required (to be purchased separately).

The integrated electronics also manage the screed heating function in order to perform the initial central heating cycle on new radiant panel systems.

13.1 USER PROGRAMMING MENU

DATA MENU		
Id Parameter	Description	Range
D 003	It displays storage tank unit temperature.	-10 ÷ 130 °C
D 004	Value calculated for system setting.	5 - 65 °C
D 005	Value set for DHW setting.	10 - 65 °C
D 006	Outdoor temperature (if the condensing unit external probe is connected or if the optional external probe is available).	- 20 - 50 °C
D 008	System return water temperature.	-10 ÷ 130 °C
D 009	List of the last five anomalies (to scroll the list press "OK").	-
D 010	Anomaly list reset. Once "D 10" is displayed, press "OK".	-
D 014	Circulator pump flow rate (l/h).	0 ÷ 9999 l/h
D 020	System flow temperature.	-10 ÷ 130 °C
D 022	DHW 3-way (DHW = domestic hot water, CH = central heating).	DHW- CH
D 024	Chiller circuit liquid phase temperature.	-10 - 130 °C
D 025	Zone 2 flow temperature (if configured).	-10 - 130 °C
D 026	Probe for primary accumulation (puffer).	-10 - 130 °C
D 028	Heat pump circulator DHW speed.	0 - 100 %
D 031	DHW integration function.	OFF - ON
D 032	System integration function.	OFF - ON
D 034	Heat pump disabling.	OFF - ON
D 035	Solar system inlet.	OFF - ON
D 036	Not used.	-
D 041	Relative humidity zone 1 (if zone 1 humidity sensor active).	0 - 99 %
D 042	Relative humidity zone 2 (if zone 2 humidity sensor active).	0 - 99 %
D 043	Zone 1 humidistat (if zone 1 humidistat active).	OFF - ON
D 044	Zone 2 humidistat (if zone 2 humidistat active).	OFF - ON
D 045	Dehumidifier zone 1.	OFF - ON
D 046	Dehumidifier zone 2.	OFF - ON
D 047	Zone 1 circulator pump.	OFF - ON
D 048	Zone 2 circulator pump.	OFF - ON
D 049	Central heating / cooling system separation 3-way (CL = cooling, HT = heating).	CL - HT
D 051	Zone 1 remote control.	OFF - ON
D 052	Zone 2 remote control.	OFF - ON
D 053	System setting with remote connection in zone 1.	5 - 65 °C
D 054	System setting with remote connection in zone 2.	5 - 65 °C
D 055	Zone 1 thermostat.	OFF - ON
D 056	Zone 2 thermostat.	OFF - ON
D 061	Device model definition (MP = MAGIS PRO V2; MCI = MAGIS COMBO V2; MCP = MAGIS COMBO PLUS V2).	MP - MCI - MCP
D 062	Communication with external condensing unit interface board.	OFF - ON
D 063	Communication with other IMMERGAS devices.	OFF - ON
D 071	Condensing unit operating frequency.	0 - 150 Hz
D 072	Condensing unit compressor temperature.	-20 - 200 °C
D 073	Condensing unit compressor discharge temperature.	-20 - 100 °C
D 074	Condensing unit evaporator coil temperature.	-20 - 100 °C

MAGIS PRO V2

DATA MENU		
Id Parameter	Description	Range
D 075	Condensing unit compressor absorption.	0 - 10 A
D 076	Condensing unit fan speed.	0 - 100 rpm
D 077	Electronic expansion valve position.	0 - 2000
D 078	4-way side (CL = cooling, HT = heating).	HT / CL
D 079	Temperature detected by the condensing unit external probe.	-55 ÷ +45 °C
D 080	Heat pump status (reserved for Technical Assistance Service).	0 ÷ 8
D 091	P.C.B. software version.	-
D 097	Heat pump demand status (reserved for Technical Assistance Service).	0 ÷ 999
D 099	System state (reserved to Technical Assistance Service).	0 ÷ 999
D 101	Zone 3 flow temperature (if configured).	-10 - 130 °C
D 102	Relative humidity zone 3 (if zone 3 humidity TEMPERATURE sensor active).	0 - 99 %
D 103	Zone 3 humidistat (if zone 3 humidistat active).	OFF - ON
D 104	Dehumidifier zone 3.	OFF - ON
D 105	Zone 3 pump.	OFF - ON
D 106	Zone 3 remote panel.	
D 107	Setpoint zone 3.	
D 108	Thermostat zone 3.	
D 120	Outdoor unit main board firmware version (1/4).	1 ÷ 99
D 121	Outdoor unit main board firmware version (2/4).	1 ÷ 99
D 122	Outdoor unit main board firmware version (3/4).	1 ÷ 99
D 123	Outdoor unit main board firmware version (4/4).	1 ÷ 99
D 124	Condensing unit interface board firmware version (1/4).	1 ÷ 99
D 125	Condensing unit interface board firmware version (2/4).	1 ÷ 99
D 126	Condensing unit interface board firmware version (3/4).	1 ÷ 99
D 127	Condensing unit interface board firmware version (4/4).	1 ÷ 99
D 128	Outdoor unit inverter board memory version (1/4).	1 ÷ 99
D 129	Outdoor unit inverter board memory version (2/4).	1 ÷ 99
D 130	Outdoor unit inverter board memory version (3/4).	1 ÷ 99
D 131	Outdoor unit inverter board memory version (4/4).	1 ÷ 99
D 132	Outdoor unit inverter board firmware version (1/4).	1 ÷ 99
D 133	Outdoor unit inverter board firmware version (2/4).	1 ÷ 99
D 134	Outdoor unit inverter board firmware version (3/4).	1 ÷ 99
D 135	Outdoor unit inverter board firmware version (4/4).	1 ÷ 99
D 140	Internal clock.	0 ÷ 23
D 141	Internal clock.	0 ÷ 59
D 142	Day of the week.	Mon - Tue - Wed - Thu - Fri - Sat - Sun
D 143	Current day.	1 ÷ 31
D 144	Current month.	1 ÷ 12
D 145	Current year.	0 ÷ 99

USER MENU				
Id Parameter	Description		Range	Default
U 001	Central heating setting zone 2 to be used in the absence of temperature control ("R01" = OFF).		20 - 65 °C	25
U 002	Cooling setting zone 2 to be used in the absence of temperature control ("R01" = OFF).		5 - 25 °C	20
U 003	Zone 1 central heating offset	You can edit the flow temperature with respect to the external probe regulation curve in central heating mode (see heat adjustment graphs).	- 15 - + 15 °C	0
U 004	Zone 2 C. H. offset		- 15 - + 15 °C	0
U 005	Zone 1 cooling offset	You can edit the flow temperature with respect to the external probe regulation curve in cooling mode (see heat adjustment graphs).	- 15 - + 15 °C	0
U 006	Zone 2 cooling offset		- 15 - + 15 °C	0
U 007	Zone 1 humidity setting	The humidity temperature sensor (optional) defines room humidity in the corresponding area.	30 - 70 %	50
U 008	Zone 2 humidity setting		30 - 70 %	50
U 011	Night function	Activating the function allows you to reduce the compressor frequency of the condensing unit in the time slot set in the U 12 and U 13 parameters. Make sure the additional power sources needed to meet potential requirements that may present themselves during active operation are available (e.g. additional resistances).	OFF - ON	OFF
U 012	Night function enabling time.		0 - 23	0
U 013	Night function disabling time.		0 - 23	0
U 014	Central heating setting zone 3 to be used in the absence of temperature control ("R01" = OFF).		20 - 65 °C	25
U 015	Cooling setting zone 3 to be used in the absence of temperature control ("R01" = OFF).		5 - 25 °C	20
U 016	Zone 3 central heating offset	You can edit the flow temperature with respect to the external probe regulation curve in cooling mode (see heat adjustment graphs).	- 15 - + 15 °C	0
U 017	Zone 3 cooling offset		- 15 - + 15 °C	0
U 018	Zone 3 humidity setting	The humidity temperature sensor (optional) defines room humidity in the corresponding area.		
U 021	Hour setting (internal clock).		0 ÷ 23 hours	-
U 022	Minutes setting (internal clock).		0 ÷ 59 minutes	-
U 023	Day of the week.		Mon - Tue - Wed - Thu - Fri - Sat - Sun	-
U 024	Current day.		1 ÷ 31	-
U 025	Current month.		1 ÷ 12	-
U 026	Current year.		00 ÷ 99	-

N.B.: The parameters referring to zone 2 can only be displayed if there is a zone 2 on the system and it is configured correctly. The parameters referring to zone 3 can only be displayed if there is a zone 3 on the system and it is configured correctly (available from revision 2.0 of the P.C.B. firmware).

MAGIS PRO V2

13.2 MAINTENANCE TECHNICIAN PROGRAMMING MENU

Id Parameter	Parameter	Description	Range	Default
A 003	Minimum pump speed	Defines the minimum operating speed of the system circulator pump.	0 - 100 %	100
A 004	Maximum pump fixed speed	Defines the maximum operating speed of the system circulator pump.	45 - 100 %	100
A 011	Condensing unit model	Establishes the condensing unit model paired with the hydronic module. If set to OFF, only the integrated generators are activated.	OFF - 4 - 6 - 9	6
A 012	System vent	Enables the automatic vent function. This function activates as soon as the unit is powered.	OFF - ON	ON
A 013	Number of zones	Defines the number of zones in the heating system.	1 - 3	1
A 014	Zone 2 max. temperature	Defines the maximum temperature acceptable by zone 2.	20 - 80 °C	45°C
A 015	Zone 3 max temperature	Defines the maximum temperature acceptable by zone 3.	20 - 80 °C	45°C
A 016	Zone 1 humidity sensor	Humidity temperature sensor / Humidistat / Remote panel / Remote panel with humidistat. Defines the type of control on zone 1 humidity.	SE = Humidity temp. sensor ST = Humidistat RP - Remote panel RPH = Remote panel with humidistat	ST
A 017	Zone 2 humidity sensor	Humidity temperature sensor / Humidistat / Remote panel / Remote panel with humidistat. Defines the type of control on zone 2 humidity.	SE = Humidity temp. sensor ST = Humidistat RP - Remote panel RPH = Remote panel with humidistat	ST
A 021	BMS communication address	Defines the communication protocol between the indoor unit and the condensing unit.	1 - 247	11
A 022	BMS communication setting	OFF = BMS communication protocol on 485; use if connected to optional Immergas devices. 485 = Do not use. UC = Do not use.	OFF - 485 - UC	OFF
A 023	Zone 3 humidity sensor	Humidity temperature sensor / Humidistat / Remote panel / Remote panel with humidistat. Defines the type of control on zone 3 humidity.	SE = Humidity temp. sensor ST = Humidistat RP - Remote panel RPH = Remote panel with humidistat	ST

A 030	Enabling DOMINUS	Allows you to enable the DOMINUS remote device.	OFF - ON	ON
A 031	Zone 1 room thermostat	Room thermostat / Remote panel / Remote panel with thermostat. Defines the temperature control in zone 1.	RT = Room thermostat RP Remote panel RPT = Remote panel with Thermostat	RT
A 032	Zone 2 room thermostat	Room thermostat / Remote panel / Remote panel with thermostat. Defines the temperature control in zone 2.	RT = Room thermostat RP Remote panel RPT = Remote panel with Thermostat	RT
A 033	Zone 3 room thermostat	Room thermostat / Remote panel / Remote panel with thermostat. Defines the temperature control in zone 3.	RT = Room thermostat RP Remote panel RPT = Remote panel with Thermostat	RT
A 039	Heating/Cooling contact	Enables the Heating/Cooling function by means of a contact.	OFF - ON	OFF
A 041	Zone 1 heating / cooling enable	Allows you to determine the operation of: Central heating / Cooling or both in zone 1.	HT / CL / H - C	H - C
A 042	Zone 2 heating / cooling enable	Allows you to determine the operation of: Central heating / Cooling or both in zone 2.	HT / CL / H - C	H - C
A 043	Zone 3 heating / cooling enable	Allows you to determine the operation of: Heating / Cooling or both in zone 3.	HT / CL / H - C	H - C

Id Parameter	Parameter	Description	Range	Default
P 003	Relay 1 (optional)	The indoor unit is set-up for functioning with the relay P.C.B. (optional), which can be configured. 0 = Off 1 = DHW recirculation 2 = General alarm 3 = Central heating / cooling mode active 4 = Puffer mode active 5 = Enabling zone 3	0 - 4	0
P 004	Relay 2 (optional)	The indoor unit is set-up for functioning with the relay P.C.B. (optional), which can be configured. 0 = Off 1 = DHW recirculation 2 = General alarm 3 = Central heating / cooling mode active 4 = Puffer mode active 5 = Enabling zone 3	0 - 4	0

MAGIS PRO V2

P 005	Relay 3 (optional)	The indoor unit is set-up for functioning with the relay P.C.B. (optional), which can be configured. 0 = Off 1 = DHW recirculation 2 = General alarm 3 = Central heating / cooling mode active 4 = Puffer mode active 5 = Enabling zone 3	0 - 4	0
P 007	External probe correction	If the reading of the external probe is not correct it is possible to correct it in order to compensate any environmental factors.	-9 - 9 K	0
P 011	DHW generator offset point	The DHW flow setpoint of the generator is calculated by adding P 011 to the DHW setpoint.	2 ÷ 30 °C	10
P 012	DHW electric resistance tripping offset	Call IMMERGAS technical service assistance.	5 - 50 °C	5
P 013	Max time anti-Legionella	Maximum time to perform anti-Legionella function.	1 ÷ 24 hours	3
P 014	Max time DHW	Maximum time to perform DHW function.	1 ÷ 24 hours	5
P 015	Anti-Legionella function enable	Enable running of anti-Legionella function.	OFF - ON	OFF
P 016	Anti-Legionella start time	Allows to set when anti-Legionella function starts.	1 ÷ 23	2
P 017	Anti-Legionella activation day	Allows to set the weekday on which to activate the anti-Legionella function. You may even activate the function continuously every day.		
P 021	Activation time	Temperature setpoint - Activation time correction.	0 ÷ 120 minutes	20
P 022	Increase time	Temperature setpoint - Increment time correction.	0 ÷ 20 minutes	5
P 023	Heat setpoint correction.	Allows to correct the heating mode demand setpoint in presence of dispersions or system decoupling circuits.	0 ÷ 10 °C	0
P 024	Cool setpoint correction.	Allows to correct the cooling mode demand setpoint in presence of dispersions or system decoupling circuits.	0 ÷ 10 °C	0

Id Parameter	Parameter	Description	Range	Default
T 002	DHW thermostat	Establishes the unit ignition and switch-off mode in DHW. It is enabled when the water in the storage tank goes below the DHW set value and is disabled when the temperature exceeds the DHW set value.	0 - 20 °C	4
T 005	Central heating ignitions timer	The hydronic module has an electronic timer, which prevents the generator from igniting too often in central heating mode.	0 - 10 minutes	3
T 007	Delay request from TA	The system is set to switch on immediately after a request for room air conditioning. For special systems (e.g. zone systems with motorised valves, etc.), it may be necessary to delay ignition.	0 - 240 seconds (step 10 sec.)	0
T 008	Display lighting	Establishes the display lighting mode. AU: the display lights up during use and lowers after 15 seconds of inactivity. In the event of an anomaly, the display flashes. OFF: the display lighting is always off. ON: the display lighting is always on.	AU - OFF - ON	AU
T 009	Display	Establishes what the indicator displays. “Summer” mode: ON: pump active displays the flow temperature, pump off the indicator is off. OFF: the indicator is always off. “Winter” and “Cooling” mode: ON: pump active displays the flow temperature, pump off the indicator is off. OFF: pump active displays the value set on the heating/cooling selector, with circulator off the indicator is off.	ON - OFF	ON
T 021	Screed heating - minimum temperature	Defines the time spent at minimum operating temperature during the active function.	0 ÷ 7 days	3
T 022	Screed heating - ascent gradient	Defines the ascent gradient of the temperature.	0 ÷ 30 °C / day	30
T 023	Screed heating - maximum temperature	Defines the time spent at maximum operating temperature during the active function.	0 ÷ 14 days	4
T 024	Screed heating - descent gradient	Defines the descent gradient of the temperature.	0 ÷ 30 °C / day	30

MAGIS PRO V2

HEAT REGULATION MENU				
Id Parameter	Parameter	Description	Range	Default
R 001	External probe	Defines if and which external probe is used to manage the system. OFF = no external probe used. OU = external probe on the outdoor condensing unit. IU = optional external probe connected to the indoor unit.	OFF - OU - IU	OU
R 002	Outdoor temperature for max. CH flow zone 1	Establishes the outdoor temperature at which to have the maximum flow temperature.	-15 - 25 °C	-5
R 003	Outdoor temperature for min. CH flow zone 1	Establishes the outdoor temperature at which to have the minimum flow temperature.	-15 - 25 °C	25
R 004	Zone 1 maximum central heating	Defines the maximum flow temperature in room central heating mode.	20 - 65 °C	45
R 005	Zone 1 minimum central heating	Defines the minimum flow temperature in room central heating mode.	20 - 65 °C	25
R 006	Outdoor temperature for max CH flow zone 2 mixed	Establishes the outdoor temperature at which to have the maximum flow temperature in the low temperature zone 2.	-15 - 25 °C	-5
R 007	Outdoor temperature for min CH flow zone 2	Establishes the outdoor temperature at which to have the minimum flow temperature in the low temperature zone 2.	-15 - 25 °C	25
R 008	Mixed zone 2 maximum central heating	Defines the maximum flow temperature in room central heating mode in the low temperature zone 2.	20 - 65 °C	40
R 009	Mixed zone 2 minimum central heating	Defines the minimum flow temperature in room central heating mode in the low temperature zone 2.	20 - 65 °C	25
R 010	Zone 1 outdoor temperature for minimum cooling flow	Establishes the maximum outdoor temperature at which to have the minimum flow temperature in cooling mode.	20 ÷ 40 °C	35
R 011	Outdoor temperature for Zone 1 maximum cooling flow	Establishes the minimum outdoor temperature at which to have the maximum flow temperature in cooling mode.	20 ÷ 40 °C	25
R 012	Zone 1 minimum cooling	Defines the minimum flow temperature in room cooling mode.	5 ÷ 20 °C	7
R 013	Zone 1 maximum cooling	Defines the maximum flow temperature in room cooling mode.	5 ÷ 25 °C	20
R 014	Outdoor temperature for zone 2 min cooling flow mixed zone	Establishes the outdoor temperature at which to have the minimum flow temperature in the low temperature zone 2.	20 ÷ 40 °C	35
R 015	Outdoor temperature for mixed zone 2 max cooling flow	Establishes the outdoor temperature at which to have the maximum flow temperature in the low temperature zone 2.	20 ÷ 40 °C	25
R 016	Mixed zone 2 minimum cooling	Defines the minimum flow temperature in room cooling mode in the low temperature zone 2.	5 ÷ 20 °C	18
R 017	Mixed zone 2 maximum cooling	Defines the maximum flow temperature in room cooling mode in the low temperature zone 2.	5 ÷ 25 °C	20
R 021	Outdoor temperature for max CH flow zone 3	Establishes the outdoor temperature at which to have the maximum flow temperature in the low temperature zone 3.	-15 - 25 °C	-5
R 022	Outdoor temperature for min CH flow zone 3	Establishes the outdoor temperature at which to have the minimum flow temperature in the low temperature zone 3.	-15 - 25 °C	25
R 023	Mixed zone 3 maximum central heating	Defines the maximum flow temperature in room central heating mode in the low temperature zone 3.	20 - 65 °C	40

R 024	Mixed zone 3 minimum central heating	Defines the minimum flow temperature in room central heating mode in the low temperature zone 3.	20 - 65 °C	25
R 025	Outdoor temperature for zone 3 min cooling flow mixed zone	Establishes the outdoor temperature at which to have the minimum flow temperature on zone 3.	20 ÷ 40 °C	35
R 026	Outdoor temperature for zone 3 max cooling flow	Establishes the outdoor temperature at which to have the maximum flow temperature on zone 3.	20 ÷ 40 °C	25
R 027	Zone 3 minimum cooling	Defines the minimum flow temperature on zone 3 room cooling mode.	5 ÷ 20 °C	18
R 028	Maximum cooling 3	Defines the maximum flow temperature on zone 3 room cooling mode.	5 ÷ 25 °C	20

N.B.: see also the graphs on the next pages.

INTEGRATION MENU				
Id Parameter	Parameter	Description	Range	Default
I 001	DHW integration enabling	Allows you to enable an alternative power source (AL) to integrate domestic hot water heating.	OFF - AL	AL
I 002	System integration enabling	Using this function, you can enable an alternative (AL) or simultaneous (CO) power source to integrate heating system central heating.	OFF - AL - CO	OFF
I 003	DHW max. wait time	Establishes the maximum amount of time before activating DHW integration.	1 - 255 minutes (in 1 minute steps)	30
I 004	Central heating max. wait time	Establishes the maximum amount of time before activating central heating integration.	1 - 255 minutes (in 1 minute steps)	45
I 006	Manual activation temperature	Establishes the outdoor temperature under which central heating integration is enabled.	15 - 35 °C	-5
I 011	Condensing unit hours of operation	Displays the hours of operation performed by the Condensing unit.	-	-
I 012	Indoor central heating unit hours of operation	Displays the hours of operation of the central electric heating resistance (optional).	-	-
I 013	Indoor D.H.W. unit hours of operation	Displays the hours of operation of the DHW electric resistance (optional).	-	-

MAGIS PRO V2

MAINTENANCE MENU				
Id Parameter	Parameter	Description	Range	Default
M 001	Venting	In the case of new central heating systems and in particular mode for floor systems, it is very important that de-aeration is performed correctly. The function consists of the cyclic activation of the pump (100 s ON, 20 s OFF) and the 3-way valve (120 s D.H.W., 120 s heating system). The function lasts for 18 hours and can be interrupted by pressing the "ESC" button and setting the function to "OFF".	OFF - ON	OFF
M 002	System circulator pump speed	Establishes the system circulator pump speed.	0 - 100%	0
M 003	DHW 3-way	Moves the 3-way motor from system to DHW.	DHW - CH	DHW
M 004	Hot/cold 3-way	Moves the cooling/heating circuit 3-way motor (outside the device).	OFF - ON	OFF
M 008	Zone 1 outdoor circulator pump	Enables the zone 1 outdoor circulator.	OFF - ON	OFF
M 009	Zone 2 outdoor circulator pump	Enables the zone 2 outdoor circulator.	OFF - ON	OFF
M 010	Mixer zone 2	Establishes zone 2 mixing valve positioning.	OFF - OPEN - CLOSE	OFF
M 011	DHW electrical resistance	Enables the DHW integrated electrical resistance.	OFF - ON	OFF
M 012	Central heating electrical resistance	Enables the central heating integrated electrical resistance.	OFF - ON	OFF
M 013	Dehumidifier zone 1	Enables the dehumidifier in zone 1.	OFF - ON	OFF
M 014	Dehumidifier zone 2	Enables the dehumidifier in zone 2.	OFF - ON	OFF
M 015	Relay 1	Enables relay 1 on the 3-relay board.	OFF - ON	OFF
M 016	Relay 2	Enables relay 2 on the 3-relay board.	OFF - ON	OFF
M 017	Relay 3	Enables relay 3 on the 3-relay board.	OFF - ON	OFF
M 018	Zone 3 outdoor circulator pump	Enables the zone 3 outdoor circulator pump.	OFF - ON	OFF
M 019	Dehumidifier zone 3	Enables the dehumidifier in zone 3.	OFF - ON	OFF
M 020	Zone 3 mixing valve	Establishes zone 3 mixing valve positioning.	OFF - OPEN - CLOSE	OFF

Accessing this menu, the unit goes into stand-by. By selecting every single parameter, you can activate a specific function for each load.

By setting the parameters in the "Heat regulation" menu, you can adjust how the system operates.
The following graphs show the default settings in the vari-

ous operating modes available both with external probe and without in relation to the different zones (direct or mixed).

Zone 1 flow temperature in central heating mode, with external probe

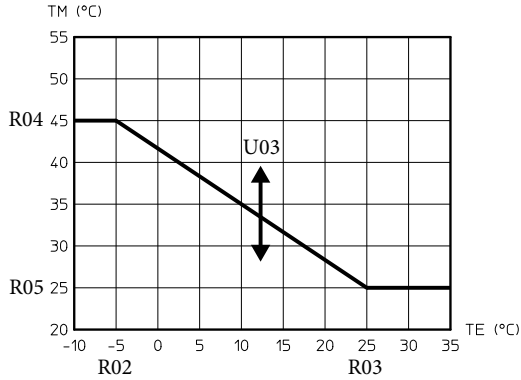

Zone 2 and 3 mixed flow temperature in central heating mode, with external probe

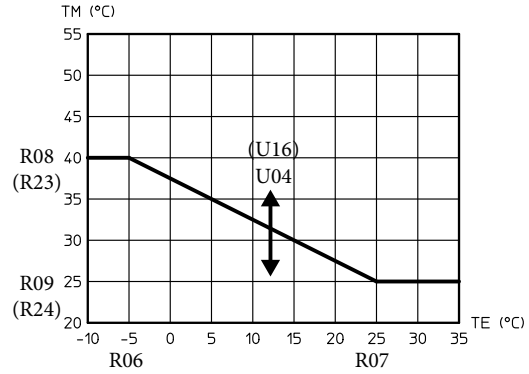

Zone 1 flow temperature in cooling mode, with external probe

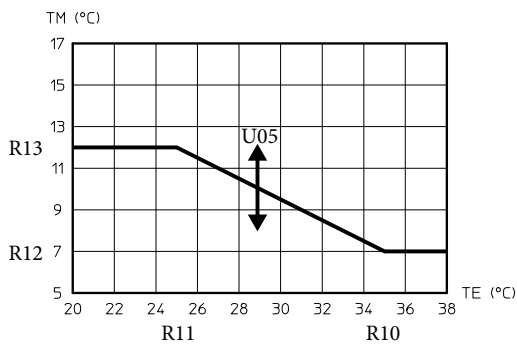

Zone 2 and 3 mixed flow temperature in cooling mode, with external probe

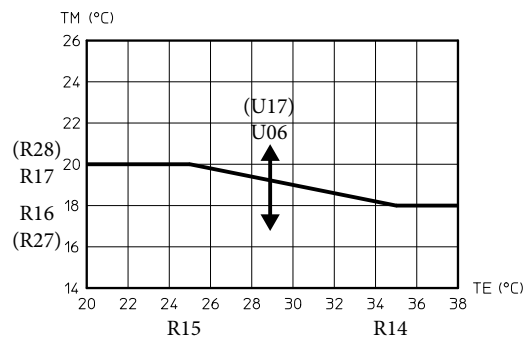

Flow temperature in central heating mode without external probe

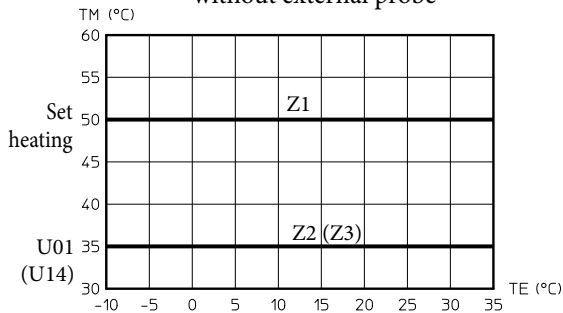

Flow temperature in cooling mode without external probe

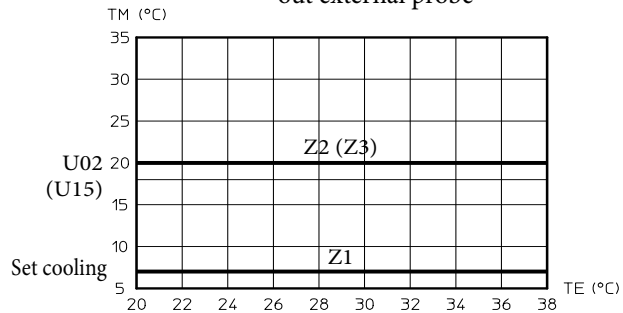

KEY:

- Rxx - "Temperature control" menu parameter
- TE - Outside temperature
- TM - Flow temperature
- U001 - Zone 2 flow temperature in "User" menu central heating mode
- U002 - Zone 2 flow temperature in "User" menu cooling mode
- U003 - Offset value compared to the curve set by the external probe on central heating zone 1.
- U004 - Offset value compared to the curve set by the external probe on central heating zone 2.
- U005 - Offset value compared to the curve set by the

- external probe on cooling zone 1.
- U006 - Offset value compared to the curve set by the external probe on cooling zone 2.
- U014 - Zone 3 flow temperature in "User" menu central heating mode.
- U015 - Zone 3 flow temperature in "User" menu cooling mode.
- U016 - Offset value compared to the curve set by the external probe on central heating zone 3.
- U017 - Offset value compared to the curve set by the external probe on cooling zone 3.
- Zx - Heating system zone

MAGIS PRO V2

14

ELECTRIC CONNECTION CABLES FEATURES

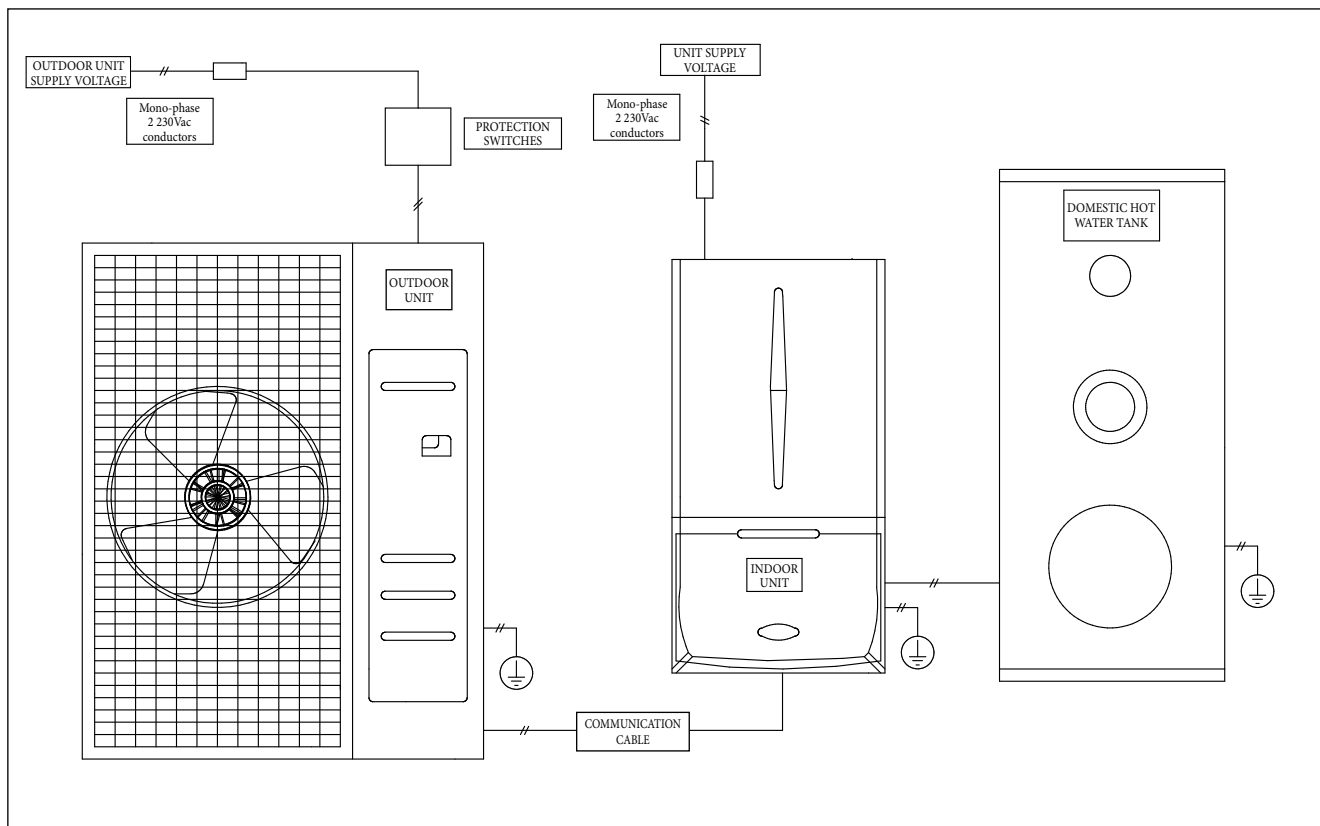

Features of the indoor unit connection. The outdoor unit power cable (not standard supplied) must be suitable for outdoor installation and must have at least a flexible polychloroprene sheath (code IEC:60245 IEC 57 / CENELEC:H05RN-F).

Indicatively, the appropriate cable section can be 2.5 mm² for AUDAX PROX 4 and 6 V2 and of 4mm² for AUDAX PRO 9 V2 to be checked depending on the specific installation conditions.

Outdoor Unit	Nominal Values		Field of Tolerable Voltage		Maximum absorbed current (MAC) in normal operation	MAC*1.25 + Additional Load	Flow rate of the protective device required for the device
	Hz	V	V	V			
AUDAX PRO 4 and 6 V2	50	220 - 240	198	264	16	20.0	20
AUDAX PRO 9 V2	50	220 - 240	198	264	22	27.5	32

Features of the connection between outdoor and indoor units.

Use H07RN-F or H05RN-F class cables to power the indoor unit.

If the indoor unit is installed in a room with a computer or internet server, you must use a double shielded FROHH2R class cable (Aluminium tape/Polyester + Copper braid).

MAGIS PRO V2 (indoor unit) supply voltage			BUS Communication cable between outdoor unit and indoor unit
Power supply	Max./Min.(V)	Connection cable	
Mono-phase, 220-240V, 50Hz	±10%	0,75 ~ 1.5 mm ² , 3 wires	0,75 ~ 1.5 mm ² , 2 wires

15 OUTDOOR UNIT TERMINAL BLOCK ELECTRICAL CONNECTIONS

With use of the mono-phase safety switch (ELB).

Depending on the model, the actual appearance of the unit may differ from the one shown in the figure.

KEY:

- ELB - Safety Switch
- MCCB - Circuit breaker switch

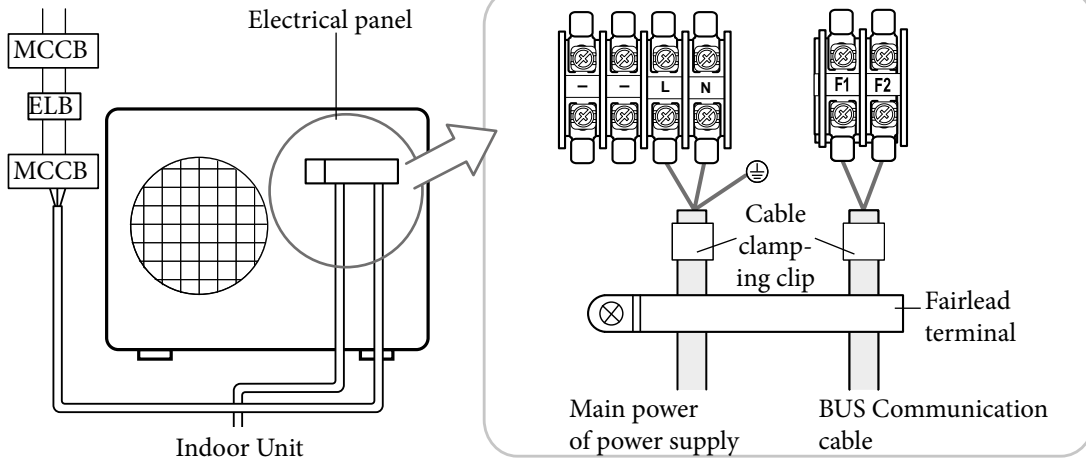

AUDAX PRO 4 and 6 V2 - Supply voltage in mono-phase AC.

M4 screw supply voltage

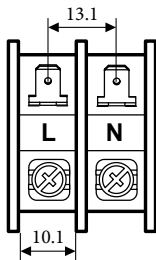

M4 screw communication BUS

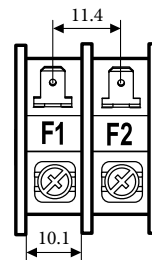

AUDAX PRO 9 V2 - Supply voltage in mono-phase AC.

Electric power supply
M5 screw

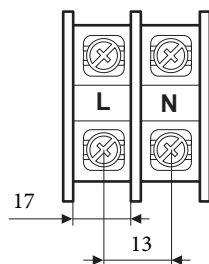

M4 screw communication
BUS

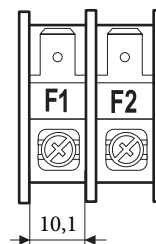

MAGIS PRO V2

16

ELECTRICAL CONNECTIONS IN HIGH VOLTAGE INDOOR UNIT

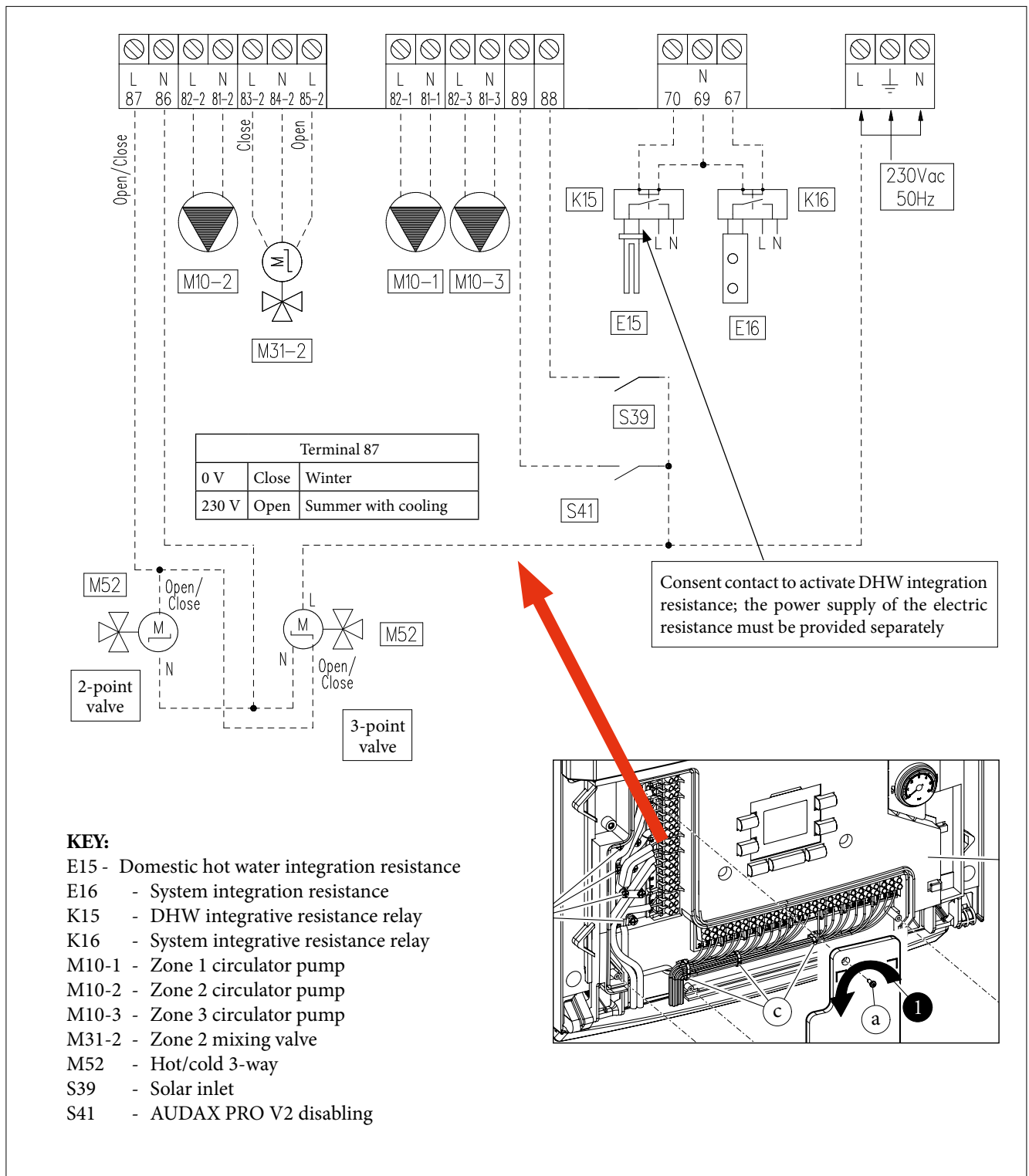

N.B.: To control the dehumidifiers, insert the relay board kit (optional) inside the MAGIS PRO V2 hydronic module, for the respective dehumidifiers of the 2 zones. The relay board kit has only one contact for each zone and, therefore, allows the dehumidifier to work either in neutral air or in cooled air. For further information see the chapter on dehumidifiers. Through the configurable relay interface kit (optional) it is also

possible to manage a 3rd zone (mixed) on the system, the pump of zone 3 will need to be connected as shown in the diagram (M10-3). The zone 3 dehumidifier, if any, will be managed by means of the configurable relay interface kit, which the zone 3 mixer will also be connected to. **In this way 1 direct zone + 2 mixed zones can be controlled.**

16.1 ELECTRICAL CONNECTIONS IN LOW VOLTAGE INDOOR UNIT

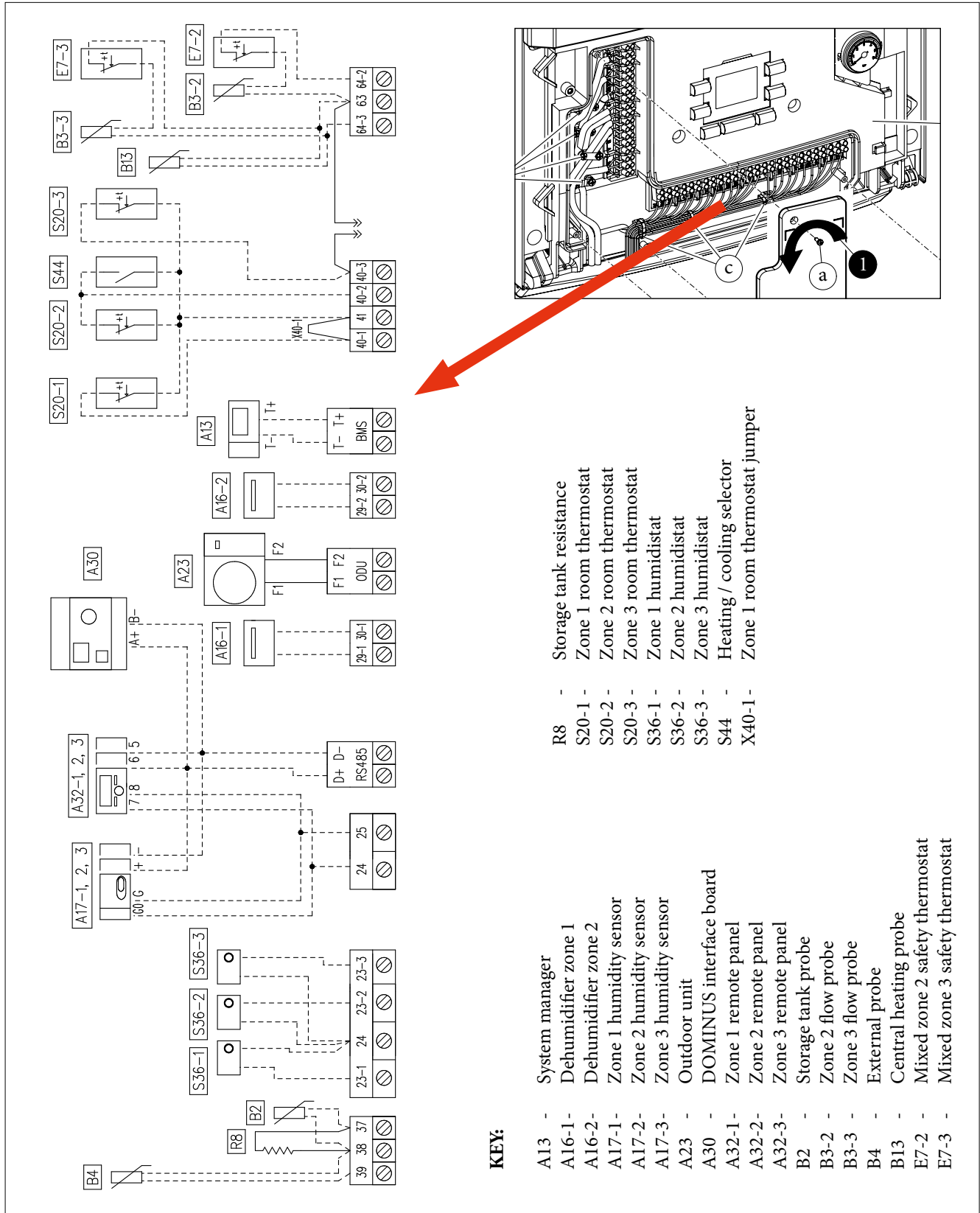

NOTES: Eliminate the X40-1 jumper before connecting the S20-1 room thermostat. When the Zone 1 remote panel is connected, hold the X40-1 jumper.

If Zone 2 and 3 remote panel is also connected, make sure there is a jumper between clamps 41 and 40-2 and 40-3.

MAGIS PRO V2

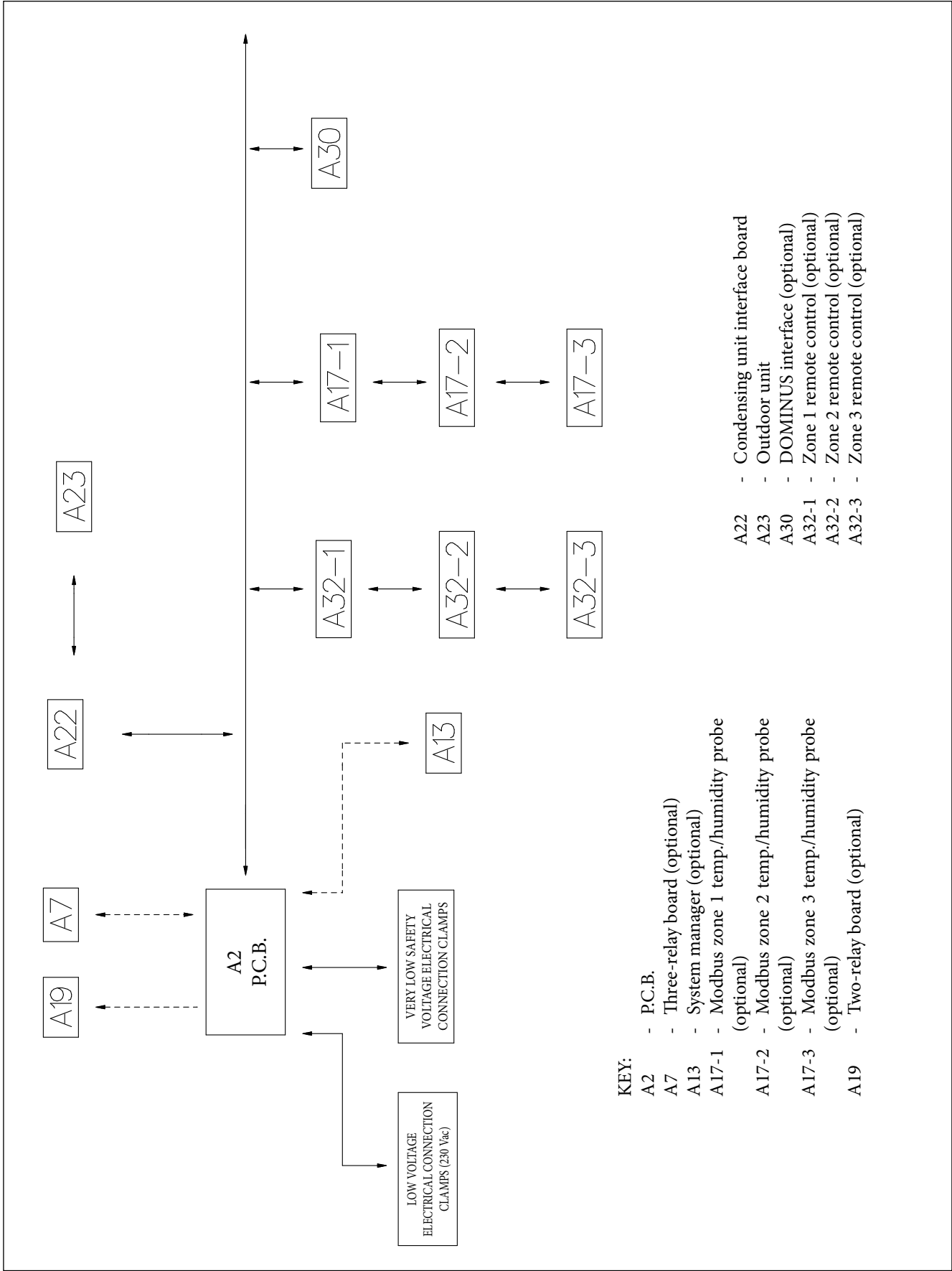

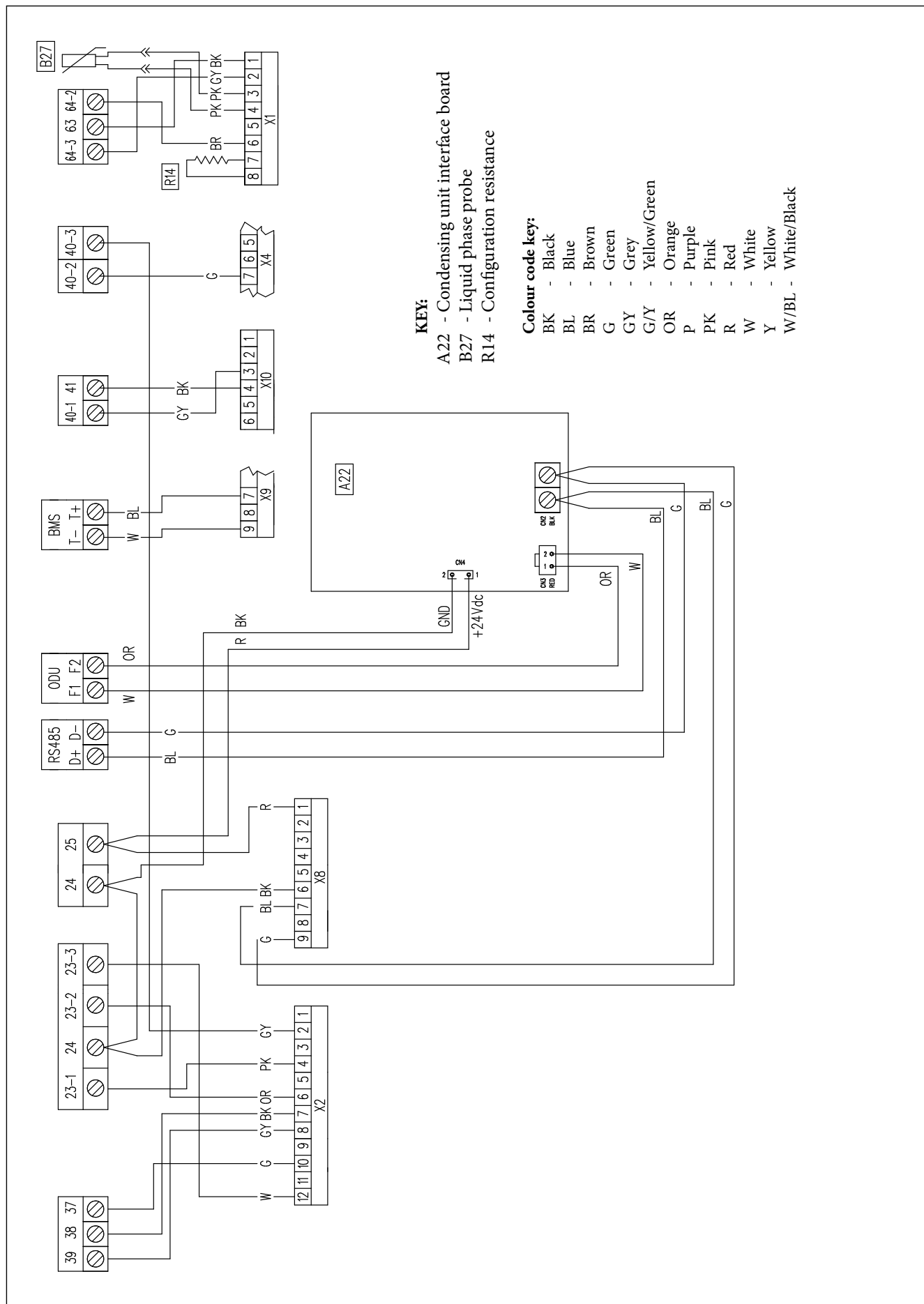

KEY:
 A22 - Condensing unit interface board
 B27 - Liquid phase probe
 R14 - Configuration resistance

Colour code key:

BK	-	Black
BL	-	Blue
BR	-	Brown
G	-	Green
GY	-	Grey
G/Y	-	Yellow/Green
OR	-	Orange
P	-	Purple
PK	-	Pink
R	-	Red
W	-	White
Y	-	Yellow
W/BL	-	White/Black

MAGIS PRO V2

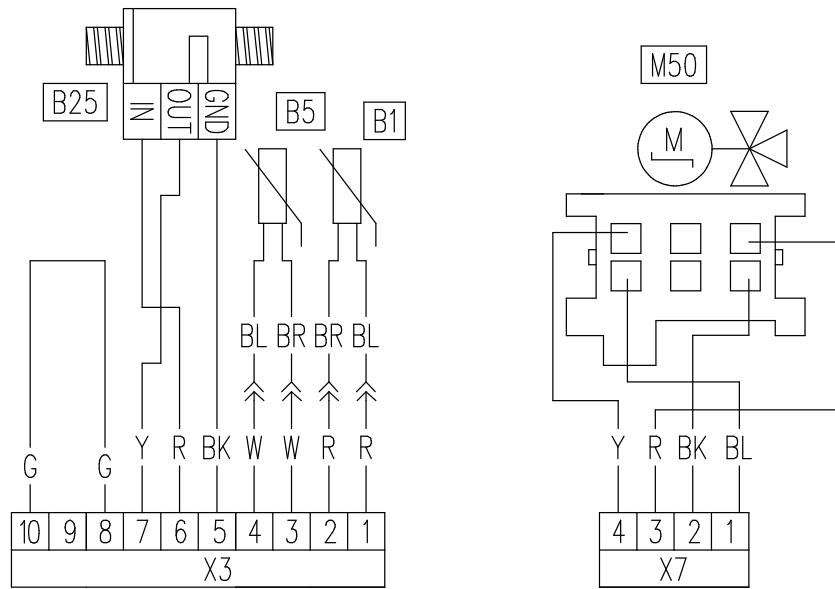

KEY:

- B1 - Heat pump flow probe
- B5 - Heat pump return probe
- B25 - System flow-meter
- M50 - DHW priority 3-way valve

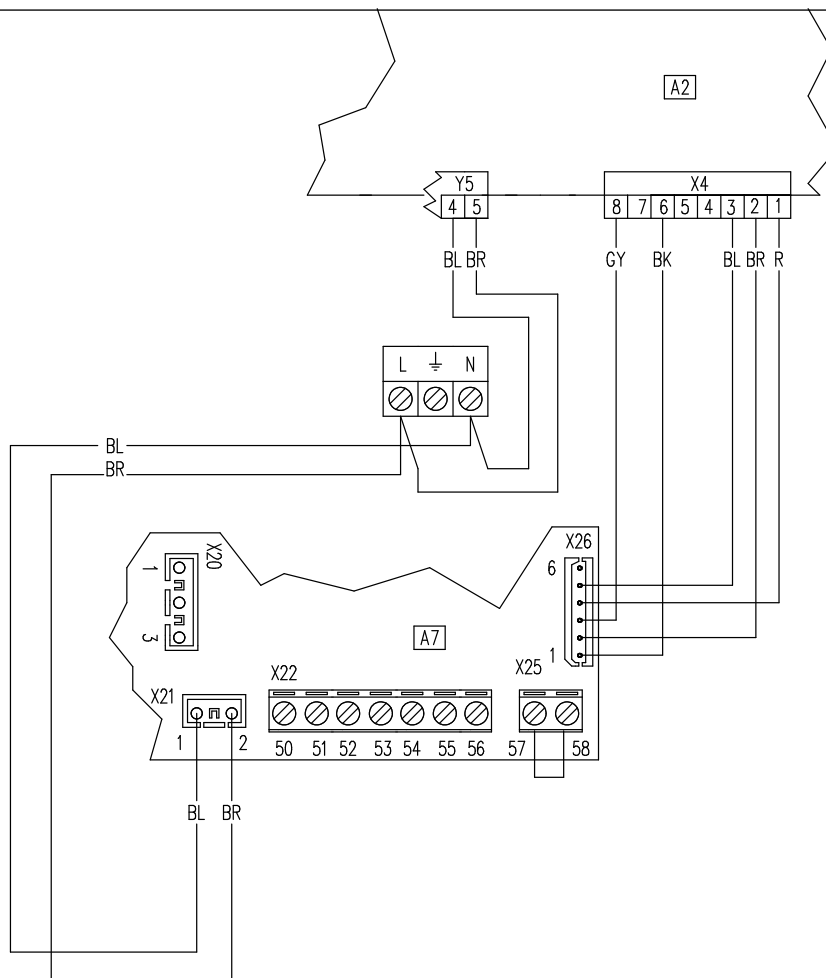

KEY:

- A2 - P.C.B.
- A17 - Three-relay board (optional)

Colour code key:

- BK - Black
- BL - Blue
- BR - Brown
- G - Green
- GY - Grey
- G/Y - Yellow/Green
- OR - Orange
- P - Purple
- PK - Pink
- R - Red
- W - White
- Y - Yellow
- W/BL - White/Black

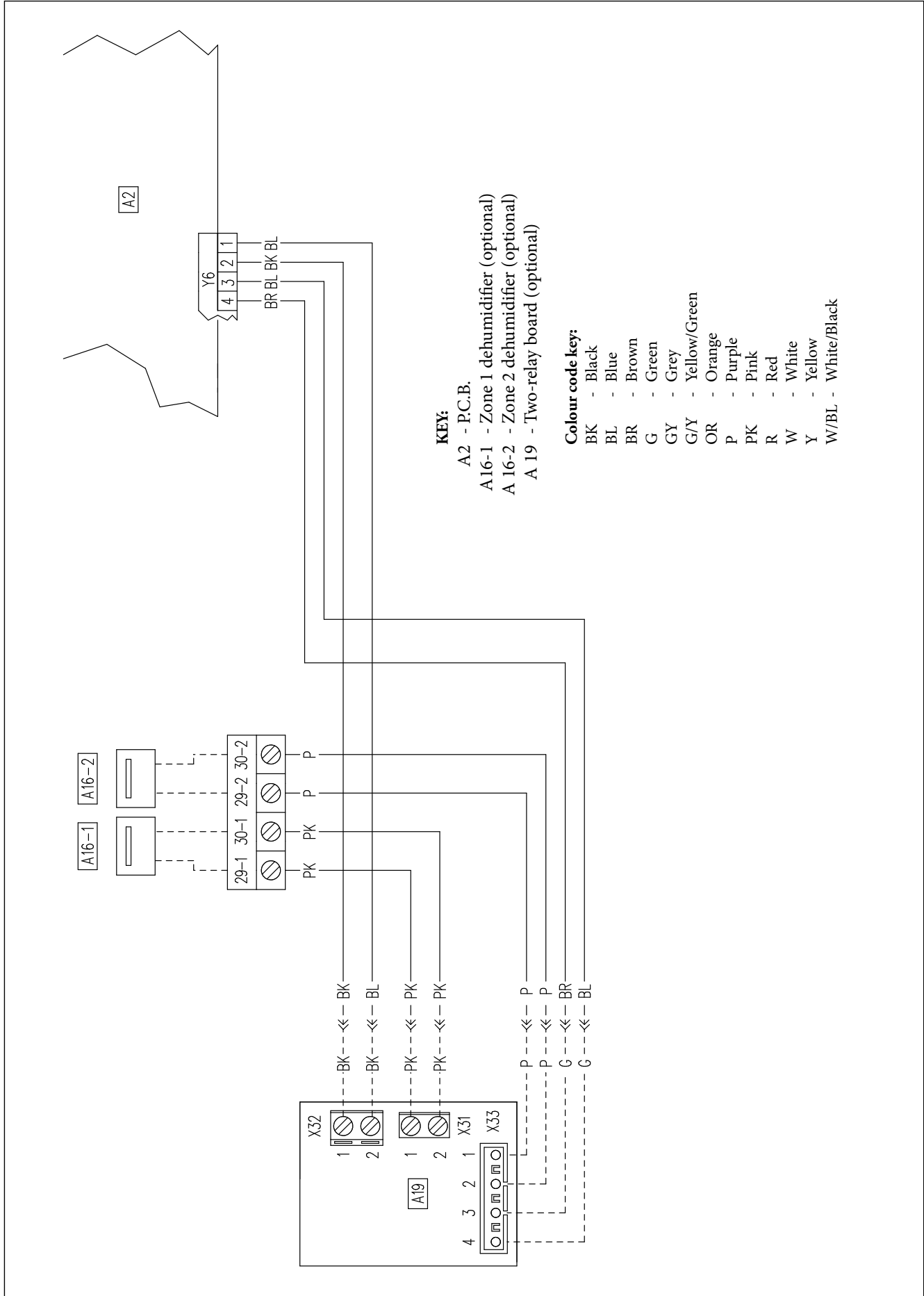

MAGIS PRO V2

18

INSTALLING THE CHILLER LINES

The MAGIS PRO V2 cooling circuit uses the refrigerant R32, therefore, it is necessary to take some measures for the proper operation of the machine:

- The R32 is a high pressure refrigerant, the pipes and other parts subject to pressure must be compliant and suitable for the refrigerant itself. Therefore, the pipes must be certified for cooling and it is necessary to observe the methods of installation stated on the instruction manual supplied with the product.
- Only use clean pipes with no harmful elements, oxides, dust, traces of iron or moisture.
- The foreign materials inside the pipes (including manufacturing oil) must be $\leq 30\text{mg}/10\text{ m}$.
- Only use equipment and fittings for R32.
- The length of the pipes between the outdoor and indoor units and the difference must not exceed the specified limits. The maximum lengths of the chiller lines are listed below, based on the condensing unit model and the type of installation:

	AUDAX PRO 4 and 6 V2	AUDAX PRO 9 V2
A	$\leq 30\text{ m}$	$\leq 35\text{ m}$
H1	$\leq 20\text{ m}$	$\leq 20\text{ m}$
H2	$\leq 15\text{ m}$	$\leq 15\text{ m}$

NOTE: it is recommendable to provide for a siphon in the immediate vicinity of the outdoor condensing unit on the gas line pipe (pipe with larger diameter).

If the length of the chiller line is greater than the one given in the machine pre-load, it is recommendable to provide for a siphon halfway.

A siphon is also recommendable in the event of installation with drops between the outdoor condensing unit and indoor unit.

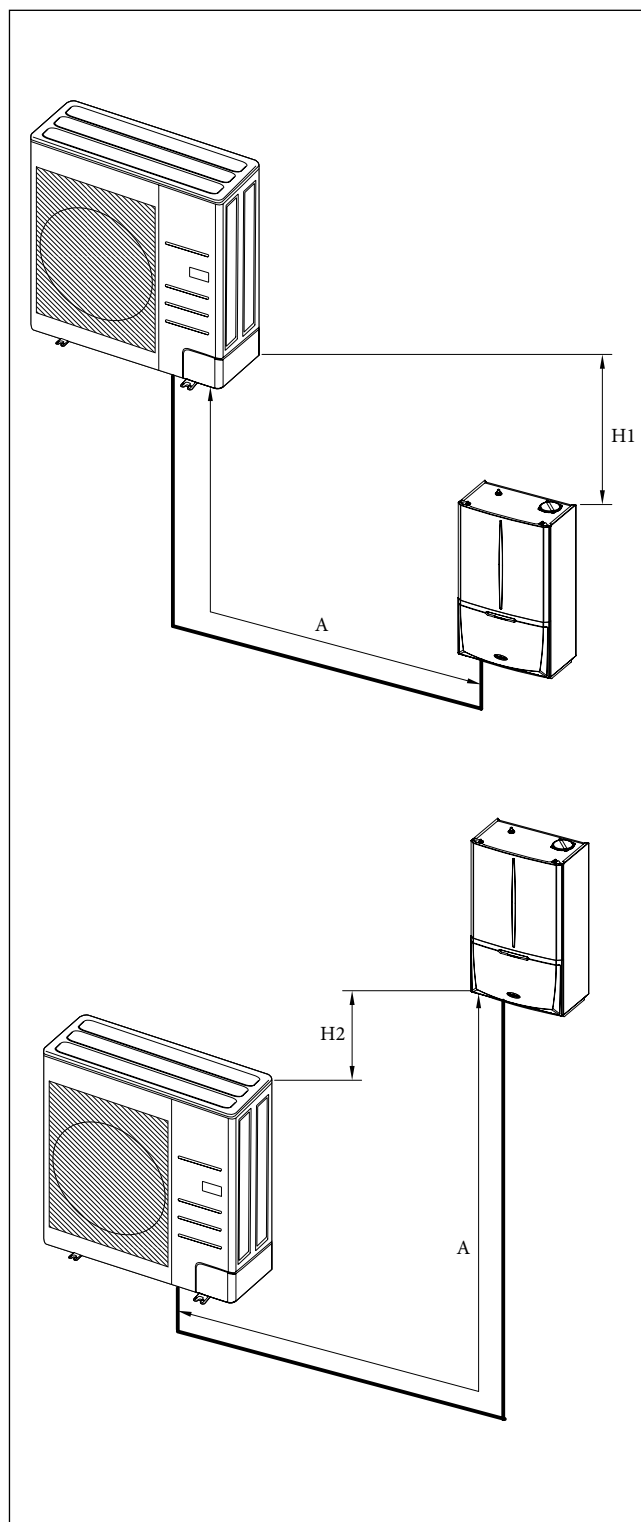

Selecting chiller line insulation.

- The gas and liquid chiller lines must be insulated with materials selected based on their respective diameters.
- Standard insulation is required at a temperature of 30°C with 85% relative humidity. Should the thermal-hygrometric conditions of the air be harsher, you must use insulations that can be selected from the table below.

NOTE: The insulation cannot be interrupted and for this reason, its junctions must be sealed with adhesive to prevent moisture from getting in.

Should the insulation be exposed to sunlight, it must be protected by wrapping it with electrical tape or material suitable for this type of application.

The insulation must be laid without its thickness being reduced in the bends and supports of the pipes.

Line	Pipe diameter (mm)	Insulation thickness		Notes
		Standard conditions (Less than 30 °C, RH 85%)	High humidity conditions (Over 30 °C, RH 85%)	
		EPDM, NBR		
Liquid	Ø 6.35 - 19.05	9	9	The pre-selected material must be able to withstand temperatures exceeding 120°C
	Ø 12.70 - 19.05	13	13	
Gas	Ø 6.35	19	19	
	Ø 9.52		25	
	Ø 12.70			
	Ø 15.88			
	Ø 19.05			

Topping up the coolant load.

Below is the default factory base load:
MAGIS PRO V2 models with R32 coolant gas:

- AUDAX PRO 4 V2 = 1.2 kg
- AUDAX PRO 6 V2 = 1.2 kg
- AUDAX PRO 9 V2 = 1.4 kg

The top-up depends on the total length and diameter of the pipes.

All the default factory loads are determined as follows, depending on the standard length of the pipes (see table below). If the used pipes are longer than stated below, the load must be topped-up in the manner and quantities described in the instruction manual supplied with the product.

NOTE: If you have already prepared chiller pipes on the 3/8" (Ø 9.52 mm) instead of 1/4" (Ø 6.35 mm) liquid line, it should be noted that up to 7 m the machine works correctly without having to add coolant gas, if you exceed this length, you must add 50 g/m linear, but never exceed the total charge of 1.84 kg of R32 coolant (take into account the amount already preloaded in the machine).

N.B.: To avoid breaking the compressor, do not top-up the coolant beyond the specified amount.

Model MAGIS PRO V2	Liquid line pipe external diameter (mm - inch)	Maximum length without base load top-up (liquid line pipe)	Top-up quantity for every additional metre of the liquid line pipe
AUDAX PRO 4 V2	Ø 6.35 - 1/4"	≤ 15 m	20 g/m
AUDAX PRO 6 V2	Ø 6.35 - 1/4"	≤ 15 m	20 g/m
AUDAX PRO 9 V2	Ø 6.35 - 1/4"	≤ 15 m	20 g/m

MAGIS PRO 4 V2

19

PRODUCT FICHE (REGULATION 811/2013)

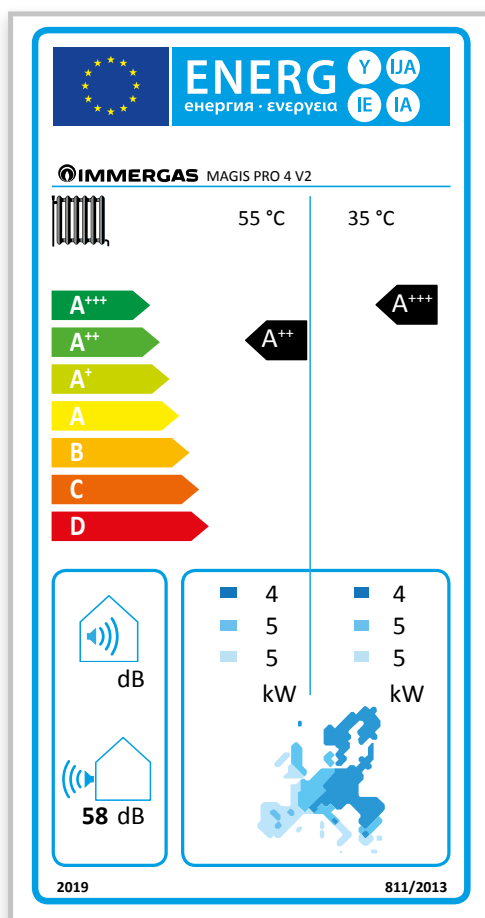

MAGIS PRO 4 V2

Low temperature (30/35)

Parameter	Value	Colder zones	Zones	Hotter zones
Annual energy consumption for the central heating mode (Q_{HE})	kWh/year	2770	2253	1134
Room central heating seasonal efficiency (η_s)	η_s %	138	180	233
Nominal heat output	kW	4.0	5.0	5.0

Average temperature (47/55)

Parameter	Value	Colder zones	Zones	Hotter zones
Annual energy consumption for the central heating mode (Q_{HE})	kWh/year	3992	3178	1753
Room central heating seasonal efficiency (η_s)	η_s %	96	127	149
Nominal heat output	kW	4.0	5.0	5.0

20

**"POWER" AND "COP" CENTRAL HEATING
MAGIS PRO 4 V2**

MAGIS PRO 4 V2		Water flow temperature °C					
		25		30		35	
Air temperature °C d.b.	(w.b.)	Max. output (kW)	Max. absorbed (kW)	Max. output (kW)	Max. absorbed (kW)	Max. output (kW)	Max. absorbed (kW)
-20	(-21)	3.76	1.21	3.65	1.30	3.48	1.46
-15	(-16)	4.28	1.28	4.16	1.37	3.96	1.54
-10	(-11)	4.87	1.32	4.73	1.41	4.51	1.59
-7	(-8)	4.97	1.29	4.83	1.38	4.60	1.55
-2	(-3)	4.75	1.10	4.62	1.18	4.40	1.33
2	(1)	4.54	0.91	4.41	0.98	4.20	1.10
7	(6)	4.75	0.70	4.62	0.75	4.40	0.85
10	(9)	5.19	0.71	5.05	0.76	4.81	0.85
15	(14)	5.92	0.72	5.76	0.77	5.48	0.87
20	(19)	6.65	0.73	6.47	0.78	6.16	0.88

MAGIS PRO 4 V2		Water flow temperature °C					
		40		45		50	
Air temperature °C d.b.	(w.b.)	Max. output (kW)	Max. absorbed (kW)	Max. output (kW)	Max. absorbed (kW)	Max. output (kW)	Max. absorbed (kW)
-20	(-21)	3.34	1.56	3.21	1.72		
-15	(-16)	3.85	1.64	3.74	1.74	3.62	1.82
-10	(-11)	4.37	1.70	4.24	1.81	4.11	1.90
-7	(-8)	4.50	1.75	4.40	1.95	4.23	2.03
-2	(-3)	4.23	1.46	4.07	1.59	3.87	1.67
2	(1)	3.97	1.16	3.73	1.23	3.55	1.38
7	(6)	4.30	0.97	4.20	1.09	4.05	1.21
10	(9)	4.71	0.97	4.61	1.10	4.38	1.23
15	(14)	5.39	0.97	5.30	1.11	5.03	1.25
20	(19)	6.07	0.99	5.98	1.12	5.68	1.26

MAGIS PRO 4 V2		Water flow temperature °C					
		55		60		65	
Air temperature °C d.b.	(w.b.)	Max. output (kW)	Max. absorbed (kW)	Max. output (kW)	Max. absorbed (kW)	Max. output (kW)	Max. absorbed (kW)
-20	(-21)						
-15	(-16)						
-10	(-11)	3.81	2.08				
-7	(-8)	4.05	2.10				
-2	(-3)	3.66	1.75	3.47	1.92		
2	(1)	3.36	1.53	3.18	1.70		
7	(6)	3.90	1.32	3.76	1.38	3.62	1.44
10	(9)	4.15	1.37	3.94	1.41	3.74	1.46
15	(14)	4.77	1.38	4.53	1.43	4.29	1.47
20	(19)	5.39	1.40	5.12	1.44	4.85	1.48

- Correction factor stated DC = 0.9

- TOL = -25 °C

MAGIS PRO 4 V2

20.1

"POWER" AND "EER" COOLING MAGIS PRO 4 V2

MAGIS PRO 4 V2	Water flow temperature °C					
	7		10		13	
Air temperature °C d.b.	Max. output (kW)	Max. absorbed (kW)	Max. output (kW)	Max. absorbed (kW)	Max. output (kW)	Max. absorbed (kW)
10	3.99	0.83	4.37	0.82	4.76	0.82
20	3.83	0.94	4.21	0.93	4.58	0.93
30	3.68	1.05	4.04	1.04	4.39	1.04
35	3.60	1.11	3.95	1.11	4.30	1.10
46	3.43	1.23	3.76	1.22	4.10	1.22

MAGIS PRO 4 V2	Water flow temperature °C					
	15		18		25	
Air temperature °C d.b.	Max. output (kW)	Max. absorbed (kW)	Max. output (kW)	Max. absorbed (kW)	Max. output (kW)	Max. absorbed (kW)
10	5.15	0.82	5.54	0.81	6.09	0.83
20	4.95	0.93	5.33	0.92	5.86	0.94
30	4.75	1.03	5.11	1.03	5.62	1.05
35	4.65	1.10	5.00	1.09	5.50	1.11
46	4.43	1.21	4.77	1.20	5.24	1.23

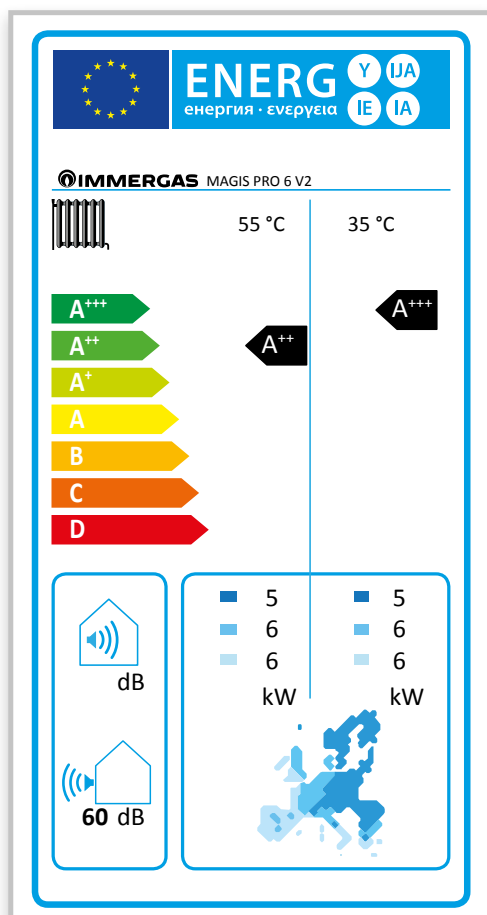

MAGIS PRO 6 V2

Low temperature (30/35)

Parameter	Value	Colder zones	Zones	Hotter zones
Annual energy consumption for the central heating mode (Q_{HE})	kWh/year	3305	2705	1264
Room central heating seasonal efficiency (η_s)	η_s %	140	180	234
Nominal heat output	kW	5.0	6.0	6.0

Average temperature (47/55)

Parameter	Value	Colder zones	Zones	Hotter zones
Annual energy consumption for the central heating mode (Q_{HE})	kWh/year	4951	3745	1953
Room central heating seasonal efficiency (η_s)	η_s %	93	129	150
Nominal heat output	kW	5.0	6.0	6.0

MAGIS PRO 6 V2

22

"POWER" AND "COP" CENTRAL HEATING MAGIS PRO 6 V2

MAGIS PRO 6 V2		Water flow temperature °C					
		25		30		35	
Air temperature °C d.b.	(w.b.)	Max. output (kW)	Max. absorbed (kW)	Max. output (kW)	Max. absorbed (kW)	Max. output (kW)	Max. absorbed (kW)
-20	(-21)	4.69	1.63	4.56	1.75	4.35	1.97
-15	(-16)	5.35	1.73	5.20	1.85	4.95	2.08
-10	(-11)	5.77	1.78	5.61	1.91	5.34	2.15
-7	(-8)	5.94	1.66	5.78	1.78	5.50	2.00
-2	(-3)	5.78	1.44	5.62	1.55	5.35	1.74
2	(1)	5.62	1.23	5.46	1.32	5.20	1.48
7	(6)	6.48	1.01	6.30	1.09	6.00	1.22
10	(9)	7.08	1.02	6.88	1.10	6.55	1.23
15	(14)	8.08	1.04	7.85	1.11	7.48	1.25
20	(19)	9.07	1.05	8.82	1.13	8.40	1.27

MAGIS PRO 6 V2		Water flow temperature °C					
		40		45		50	
Air temperature °C d.b.	(w.b.)	Max. output (kW)	Max. absorbed (kW)	Max. output (kW)	Max. absorbed (kW)	Max. output (kW)	Max. absorbed (kW)
-20	(-21)	4.18	2.10	4.01	2.32		
-15	(-16)	4.81	2.21	4.67	2.34	4.53	2.46
-10	(-11)	5.18	2.29	5.02	2.43	4.87	2.55
-7	(-8)	5.38	2.26	5.27	2.51	5.05	2.68
-2	(-3)	5.15	1.91	4.94	2.08	4.70	2.34
2	(1)	4.91	1.57	4.62	1.65	4.39	1.86
7	(6)	5.70	1.37	5.40	1.51	5.10	1.66
10	(9)	6.30	1.38	6.04	1.53	5.74	1.73
15	(14)	7.29	1.39	7.10	1.57	6.74	1.77
20	(19)	8.28	1.42	8.16	1.61	7.75	1.81

MAGIS PRO 6 V2		Water flow temperature °C					
		55		60		65	
Air temperature °C d.b.	(w.b.)	Max. output (kW)	Max. absorbed (kW)	Max. output (kW)	Max. absorbed (kW)	Max. output (kW)	Max. absorbed (kW)
-20	(-21)						
-15	(-16)						
-10	(-11)	4.52	2.80				
-7	(-8)	4.84	2.84				
-2	(-3)	4.45	2.60	4.22	2.89		
2	(1)	4.16	2.06	3.94	2.29		
7	(6)	4.80	1.81	4.53	1.88	4.27	1.95
10	(9)	5.43	1.92	5.16	1.98	4.89	2.04
15	(14)	6.39	1.97	6.07	2.03	5.75	2.09
20	(19)	7.34	2.01	6.98	2.08	6.61	2.14

- Correction factor stated DC = 0.9

- TOL = -25 °C

22.1
**"POWER" AND "EER" COOLING
MAGIS PRO 6 V2**

MAGIS PRO 6 V2	Water flow temperature °C					
	7		10		13	
Air temperature °C d.b.	Max. output (kW)	Max. absorbed (kW)	Max. output (kW)	Max. absorbed (kW)	Max. output (kW)	Max. absorbed (kW)
10	5.20	1.07	5.70	1.08	6.20	1.08
20	5.01	1.22	5.48	1.22	5.96	1.23
30	4.80	1.36	5.26	1.37	5.72	1.37
35	4.70	1.44	5.15	1.45	5.60	1.46
46	4.48	1.59	4.91	1.60	5.34	1.61

MAGIS PRO 6 V2	Water flow temperature °C					
	15		18		25	
Air temperature °C d.b.	Max. output (kW)	Max. absorbed (kW)	Max. output (kW)	Max. absorbed (kW)	Max. output (kW)	Max. absorbed (kW)
10	6.70	1.09	7.20	1.10	7.92	1.12
20	6.44	1.24	6.92	1.24	7.61	1.27
30	6.18	1.38	6.64	1.39	7.31	1.42
35	6.05	1.46	6.50	1.47	7.15	1.50
46	5.77	1.62	6.19	1.62	6.81	1.66

MAGIS PRO 9 V2

23

PRODUCT FICHE (REGULATION 811/2013)

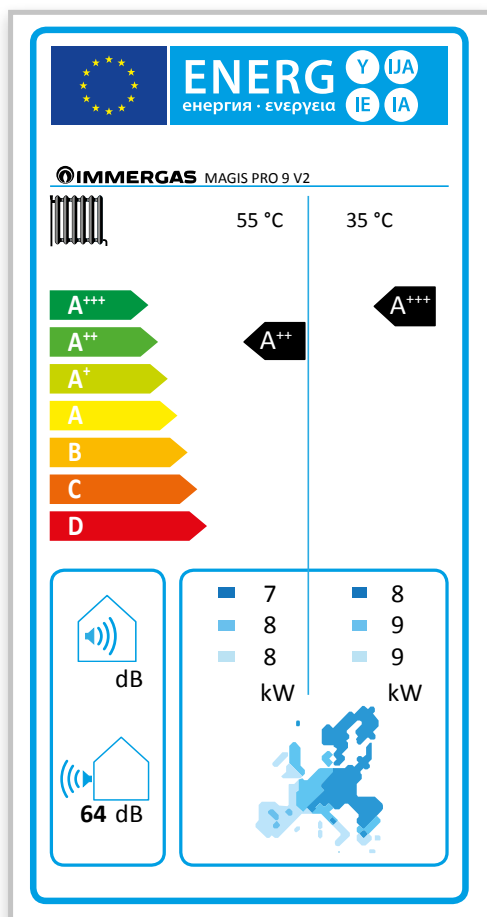

MAGIS PRO 9 V2

Low temperature (30/35)

Parameter	Value	Colder zones	Zones zones	Hotter zones
Annual energy consumption for the central heating mode (Q_{HE})	kWh/year	5252	3949	1865
Room central heating seasonal efficiency (η_s)	η_s %	138	175	241
Nominal heat output	kW	8.0	9.0	9.0

Average temperature (47/55)

Parameter	Value	Colder zones	Zones zones	Hotter zones
Annual energy consumption for the central heating mode (Q_{HE})	kWh/year	7220	5103	2720
Room central heating seasonal efficiency (η_s)	η_s %	93	127	154
Nominal heat output	kW	7.0	8.0	8.0

**24 "POWER" AND "COP" CENTRAL HEATING
MAGIS PRO 9 V2**

MAGIS PRO 9 V2		Water flow temperature °C					
		25		30		35	
Air temperature °C d.b.	(w.b.)	Max. output (kW)	Max. absorbed (kW)	Max. output (kW)	Max. absorbed (kW)	Max. output (kW)	Max. absorbed (kW)
-20	(-21)	6.90	2.28	6.71	2.44	6.39	2.74
-15	(-16)	7.86	2.41	7.64	2.58	7.28	2.90
-10	(-11)	8.47	2.52	8.23	2.70	7.84	3.04
-7	(-8)	8.53	2.41	8.30	2.58	7.90	2.90
-2	(-3)	8.42	2.14	8.19	2.30	7.80	2.58
2	(1)	8.32	1.88	8.09	2.01	7.70	2.26
7	(6)	9.72	1.55	9.45	1.66	9.00	1.87
10	(9)	10.62	1.57	10.32	1.68	9.83	1.89
15	(14)	12.11	1.59	11.78	1.70	11.22	1.91
20	(19)	13.61	1.61	13.23	1.73	12.60	1.94

MAGIS PRO 9 V2		Water flow temperature °C					
		40		45		50	
Air temperature °C d.b.	(w.b.)	Max. output (kW)	Max. absorbed (kW)	Max. output (kW)	Max. absorbed (kW)	Max. output (kW)	Max. absorbed (kW)
-20	(-21)	6.14	2.93	5.90	3.23		
-15	(-16)	7.07	3.08	6.87	3.26	6.66	3.43
-10	(-11)	7.60	3.21	7.37	3.39	7.15	3.56
-7	(-8)	7.73	3.27	7.56	3.65	7.26	3.88
-2	(-3)	7.50	2.83	7.20	3.08	6.84	3.47
2	(1)	7.27	2.39	6.84	2.52	6.50	2.84
7	(6)	8.80	2.10	8.60	2.33	8.30	2.53
10	(9)	9.64	2.12	9.44	2.36	8.97	2.66
15	(14)	11.03	2.13	10.84	2.42	10.30	2.72
20	(19)	12.42	2.18	12.24	2.47	11.63	2.78

MAGIS PRO 9 V2		Water flow temperature °C					
		55		60		65	
Air temperature °C d.b.	(w.b.)	Max. output (kW)	Max. absorbed (kW)	Max. output (kW)	Max. absorbed (kW)	Max. output (kW)	Max. absorbed (kW)
-20	(-21)						
-15	(-16)						
-10	(-11)	6.63	3.90				
-7	(-8)	6.96	4.12				
-2	(-3)	6.48	3.85	6.14	4.28		
2	(1)	6.16	3.15	5.84	3.50		
7	(6)	8.00	2.73	7.72	2.96	7.44	3.20
10	(9)	8.50	2.95	8.07	3.05	7.65	3.14
15	(14)	9.76	3.02	9.27	3.11	8.78	3.21
20	(19)	11.02	3.09	10.47	3.18	9.91	3.28

- Correction factor stated DC = 0.9
 - TOL = -25 °C

MAGIS PRO 9 V2

24.1

"POWER" AND "EER" COOLING MAGIS PRO 9 V2

MAGIS PRO 9 V2	Water flow temperature °C					
	7		10		13	
Air temperature °C d.b.	Max. output (kW)	Max. absorbed (kW)	Max. output (kW)	Max. absorbed (kW)	Max. output (kW)	Max. absorbed (kW)
10	7.20	1.45	7.80	1.48	8.41	1.51
20	6.92	1.65	7.51	1.68	8.09	1.72
30	6.64	1.84	7.21	1.88	7.77	1.92
35	6.50	1.95	7.05	1.99	7.60	2.03
46	6.19	2.15	6.72	2.20	7.24	2.24

MAGIS PRO 9 V2	Water flow temperature °C					
	15		18		25	
Air temperature °C d.b.	Max. output (kW)	Max. absorbed (kW)	Max. output (kW)	Max. absorbed (kW)	Max. output (kW)	Max. absorbed (kW)
10	9.02	1.54	9.63	1.57	10.59	1.60
20	8.68	1.75	9.27	1.78	10.19	1.82
30	8.33	1.96	8.89	1.99	9.78	2.03
35	8.15	2.07	8.70	2.11	9.57	2.15
46	7.77	2.29	8.29	2.33	9.12	2.38

	MAGIS PRO 4 V2		6 V2	9 V2
Central heating circuit				
Power in CH mode with water set at 35 °C ⁽¹⁾	kW	4.40	6.00	9.00
Power in CH mode with water set at 45 °C ⁽²⁾	kW	4.20	5.40	8.60
Power in CH mode with water set at 55 °C ⁽³⁾	kW	3.90	4.80	8.00
CH mode COP with water set at 35 °C ⁽¹⁾		5.20	4.92	4.81
CH mode COP with water set at 45 °C ⁽²⁾		3.85	3.58	3.69
CH mode COP with water set at 55 °C ⁽³⁾		2.95	2.65	2.93
Flow temperature range	°C	20 / 65	20 / 65	20 / 65
Outdoor temp. limits for Heating mode operation	°C	- 25 / 35	- 25 / 35	- 25 / 35
Cooling circuit				
Power in cooling mode with water set at 18 °C ⁽¹⁾	kW	5.00	6.50	8.70
Power in cooling mode with water set at 7 °C ⁽²⁾	kW	3.60	4.70	6.50
Cooling mode EER with water set at 18 °C ⁽¹⁾		4.59	4.42	4.12
Cooling mode EER with water set at 7 °C ⁽²⁾		3.24	3.26	3.33
Flow temperature range	°C	5 / 25	5 / 25	5 / 25
Outdoor temp. limits for Cooling mode operation	°C	10 / 46	10 / 46	10 / 46
Maximum power absorbed (condensing unit + hydronic module)	W	2100	2900	4300
General data				
Max hydraulic system operating	bar	3	3	3
Max. head available to the system (with 1000 l/h flow rate)	kPa (m H ₂ O)	51.1 (5.2)	51.1 (5.2)	51.1 (5.2)
System expansion vessel nominal capacity	litres	12	12	12
Water circuit content	litres	4.0	4.0	4.0
C.H. sound power level	dB(A)	58	60	64
Hydronic module electric degree of protection	IP	X4D	X4D	X4D
Electric power supply	V - Hz	230-50	230-50	230-50
Permitted voltage range	V	198-264	198-264	198-264
Maximum absorbed current in normal operation	A	16	16	22
Fuse required	A	20	20	32
Refrigerant fluid load (R32)	g	1200	1200	1400
Condensing unit weight (net / gross)	kg	46.5 / 49.5	46.5 / 49.5	73.0 / 81.5
Empty/full hydronic module weight	kg	35.8 / 39,8	35.8 / 39,8	35.8 / 39,8

THE REPORTED DATA REFERS TO THE FOLLOWING CONDITIONS (in compliance with EN 14511):

ROOM	HEATING PHASE (°C)	COOLING PHASE (°C)
Water TEMP. (F/R) ⁽¹⁾ - AIR (db/wb)	35/30 - 7/6	18/23 - 35 (bs)
Water TEMP. (F/R) ⁽²⁾ - AIR (db/wb)	45/40 - 7/6	7/12 - 35 (bs)
Water TEMP. (F/R) ⁽³⁾ - AIR (db/wb)	55/47 - 7/6	

MAGIS PRO V2

25.1

TECHNICAL DATA

System circuit (hydronic module)		
Adjustable central heating temperature (max operating field)	°C	20 - 65
System max. working temperature	°C	70
Cooling adjustable temperature (max. operating field)	°C	5 - 25
System max. working pressure	bar	3
System expansion vessel nominal/(real) capacity	litres	12 / (11.7)
System expansion vessel factory-set pressure	bar	1.0
Head available with 1000 l/h flow rate	kPa (m H ₂ O)	51.0 (5.1)
DHW circuit (hydronic module)		
Domestic hot water adjustable temperature	°C	10 - 55
Domestic hot water adjustable temperature with DHW integration resistance (Optional)	°C	10 - 65
General data (hydronic module)		
Electric power supply	V/Hz	230 - 50
Absorbed power without additional loads	W	65
Maximum absorbed power with additional loads	W	170
Power absorbed by pump (max. speed)	W	75
EEI value		≤ 0.20 - Part. 3
System integrative resistance absorption (optional)	kW	3
Electric insulation rating	IP	X4D
Water content	litres	4.0
Empty hydronic module weight	kg	33.5
Full hydronic module weight	kg	37.5

26 KIT 2 ZONES FOR COUPLING MAGIS PRO V2 (CODE 3.026301)



The 2 zone kit for coupling with MAGIS PRO V2 is composed of a frame, open hydraulic manifold, low electric consumption solenoid valves, three-way mixing valve, hydraulic fitting and pipes and thermometers for temperature reading. The pumps included in the kit are distinguished for being very elastic, also thanks to the 7 operating curves that can be pre-set. All components are already assembled and ready to operate. All electrical connections are to be taken to the MAGIS PRO V2 P.C.B.

This kit is to be used to control differential temperature systems and/or divided into two distinct zones.

With the acquisition of the outdoor temperature, the MAGIS PRO V2 electronics enables you to select independent flow temperature curves for each of the 2 zones of the system (both with C.H. and cooling).

Inserting these kits into the technological system enhance overall comfort and energy savings.

26.1 DIMENSIONS AND CONNECTIONS

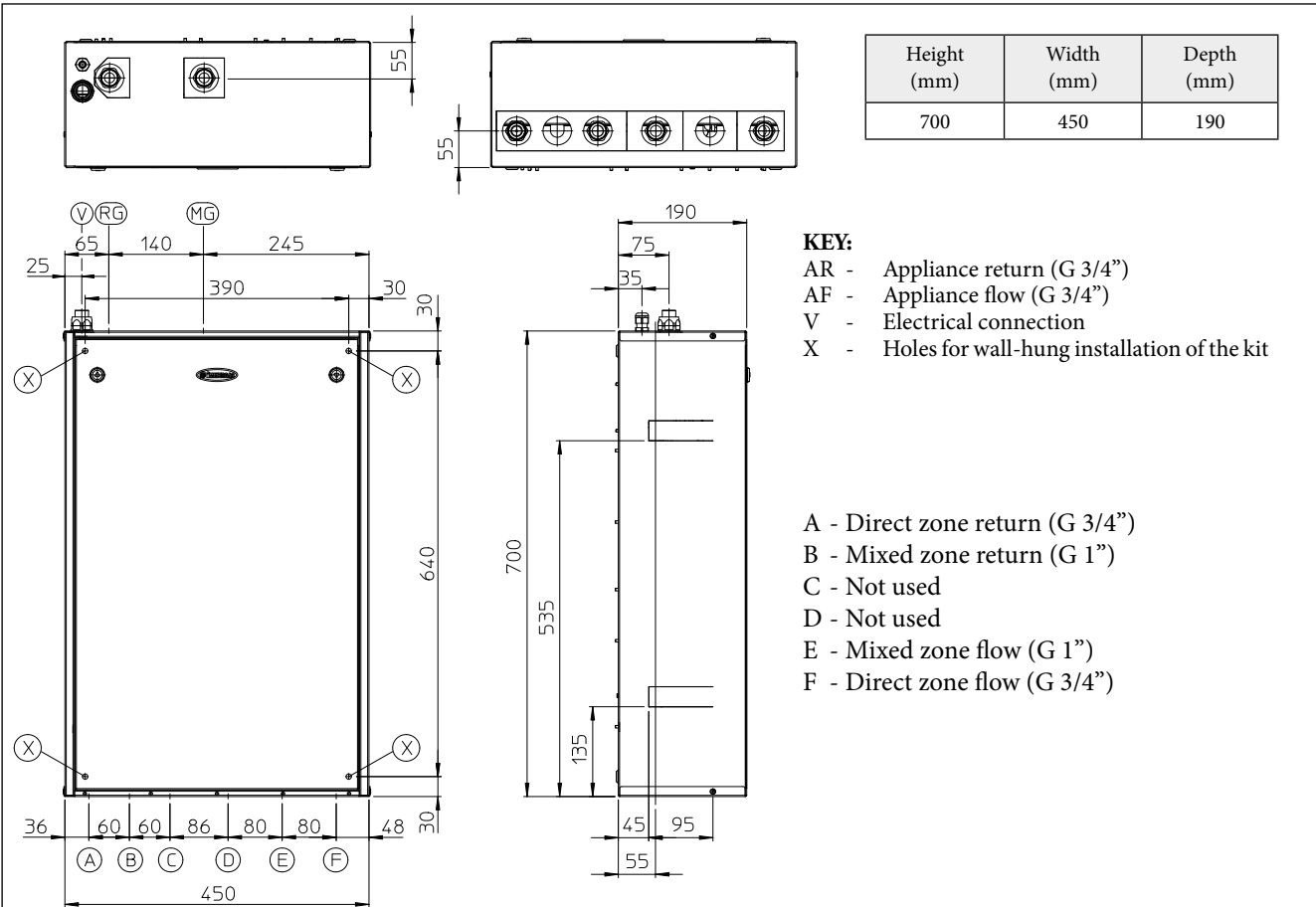

MAGIS PRO V2

26.2

MAIN COMPONENTS KIT 2 ZONES FOR COUPLING MAGIS PRO V2

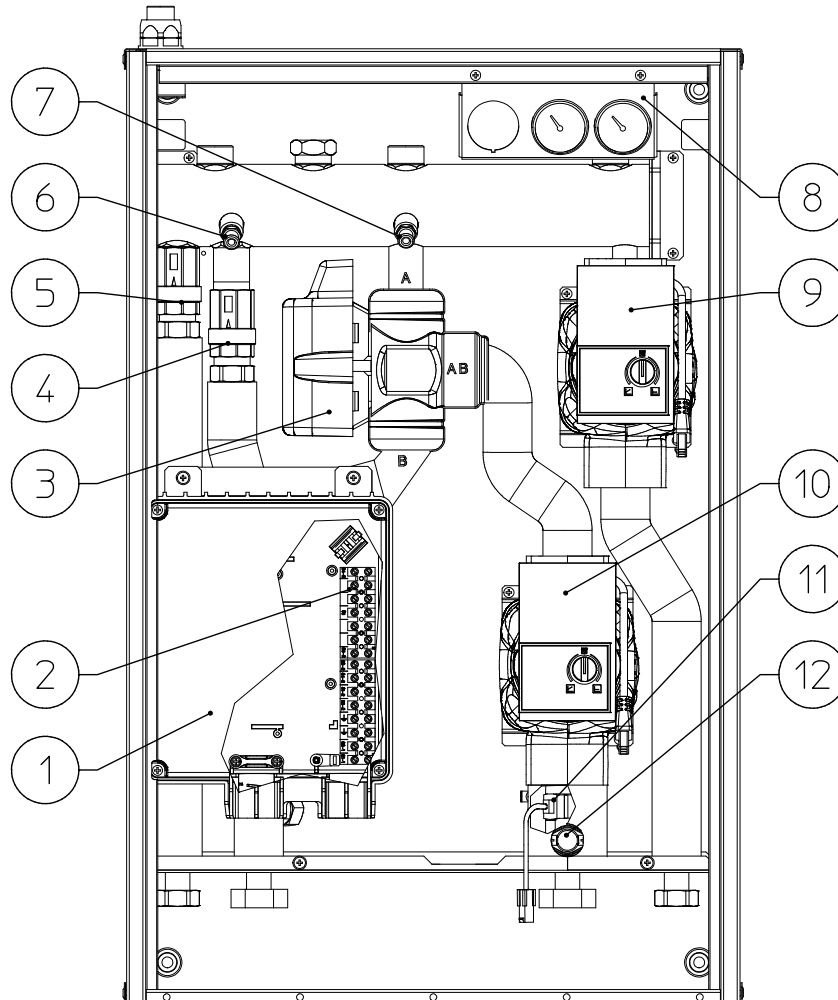

↑ ↑
RZ1 RZ2

↓ ↓
MZ2 MZ1

KEY:

- 1 - Connections box
- 2 - Connections terminal board
- 3 - Mixing valve
- 4 - Mixed zone return circuit "Europa" one-way valve
- 5 - Direct zone return circuit "Europa" one-way valve
- 6 - Drain fitting
- 7 - Drain fitting
- 8 - Flow temperature thermometers
- 9 - Direct zone pump
- 10 - Mixed zone pump
- 11 - Mixed zone flow probe
- 12 - Safety thermostat mixed zone

26.3

WIRING DIAGRAM KIT 2 ZONES FOR COUPLING MAGIS PRO V2

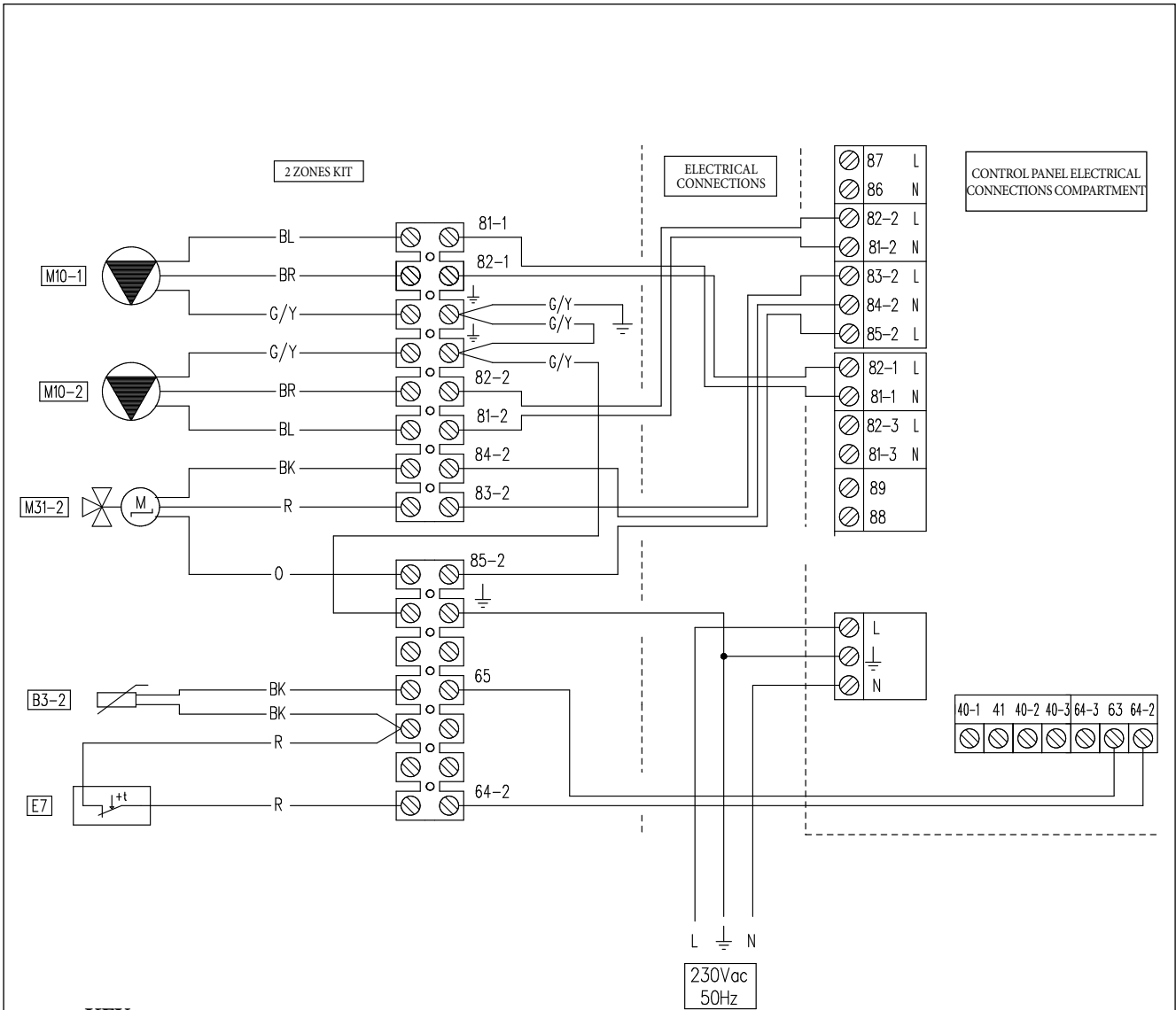

- KEY:**
- B3-2 - Zone 2 flow probe
 - E7 - Mixed zone 2 safety thermostat
 - M10-1 - Zone 1 circulator pump
 - M10-2 - Zone 2 circulator pump
 - M31-2 - Zone 2 mixing valve

- Colour code key:**
- BK - Black
 - BL - Blue
 - BR - Brown
 - G/Y - Yellow/Green
 - O - Orange
 - R - Red

MAGIS PRO V2

26.4

TECHNICAL DATA

		2 zones kit for MAGIS PRO V2
Maximum nominal pressure	bar	3
Water content in device	litres	1.5
Total head available in non-mixed zone with 1000 l/h flow rate (max.)	kPa (m H ₂ O)	49.4 (5.00)
Total head available in mixed zone (mixing valve open) with 1000 l/h flow rate (max.)	kPa (m H ₂ O)	46.8 (4.80)
Empty device weight	kg	21.1
Full device weight	kg	22.6
Electrical connection	V/Hz	230/50
Maximum input	A	0.7
Installed electric power	W	135
EEl value	-	≤ 0.20 - Part. 3
Electric plant protection	-	IPX4D
Hydraulic side generator - kit maximum distance	m	15

26.5

CIRCULATION PUMP SETTINGS AND CONFIGURATIONS

The kits are supplied with circulating pumps fitted with speed regulator. These settings are suitable for most systems.

For proper operation one must select the most suitable type of operation for the system and select a speed between 1 and 7.

- **Program constant head ($\Delta P C$)**. The circulator pump maintains the pressure level (head) constant as the system heat demand decreases (flow rate reduction). With these settings, the circulator pump is suitable for all floor systems where all the circuits must be balanced for the same drop in head. One can select the operating level from minimum to maximum by turning the selector switch clockwise in the relative power scale (refer to the drawing below).

- **Program proportional head ($\Delta P V$)**. This allows the pressure level (head) to be proportionally reduced as the system heat demand decreases (flow rate reduction). Thanks to this function, the electric power consumption of the circulator pump is reduced further: the energy (power) used by the pump decreases according to the pressure level and flow rate. With this setting, the pump guarantees optimal performance in most heating systems, proving particularly suitable in single-pipe and two-pipe installations. Any noise originating from the water flow in the pipes, valves and radiators is eliminated by reducing the head. One can select the operating level from minimum to maximum by turning the selector switch anticlockwise on the relative power scale (refer to the drawing below).

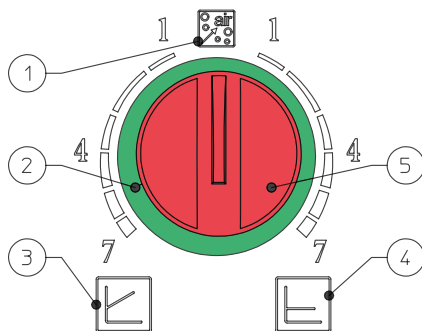

KEY:

- 1 - Automatic vent mode operation
- 2 - Light ring to indicate the operating status
- 3 - Proportional head operation
- 4 - Constant head operation
- 5 - Operating mode selector switch

26.6 GRAPHICS PUMPS WITH CONSTANT HEAD PROGRAM

The kit contains an electronic low consumption circulation pump, whose flow rate/head features are shown in the graph below.

All pumps in the kit are suitable for operation with heat and cold carrying fluid.

WILO YONOS PARA RS 15-7 RKA CM 130

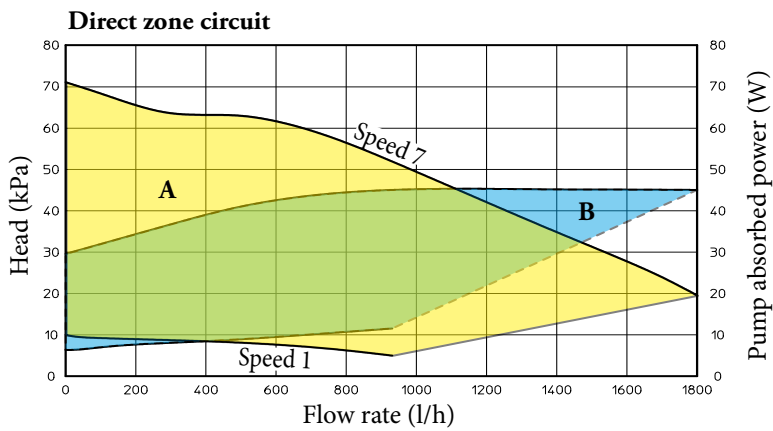
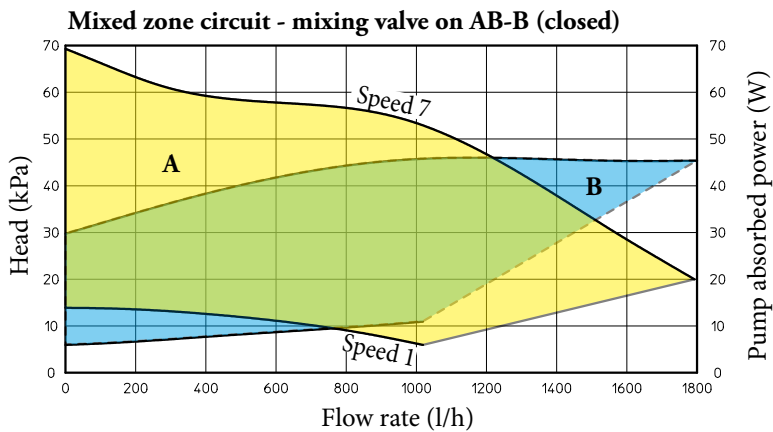
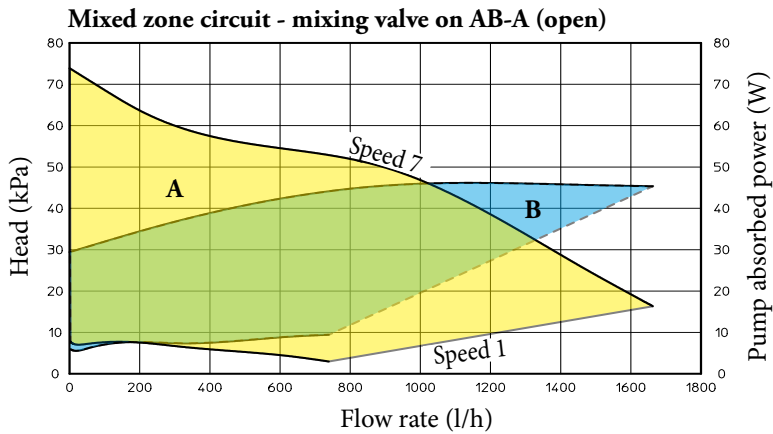

KEY:
 A = Head available at speed 1 ÷ 7
 B = Power absorbed by the system pump (dotted area)

EEI ≤ 0.20

MAGIS PRO V2

26.7

GRAPHICS PUMPS WITH PROPORTIONAL HEAD PROGRAM

The kit contains an electronic low consumption circulation pump, whose flow rate/head features are shown in the graph below.

All pumps in the kit are suitable for operation with heat and cold carrying fluid.

WILO YONOS PARA RS 15-7 RKA CM 130

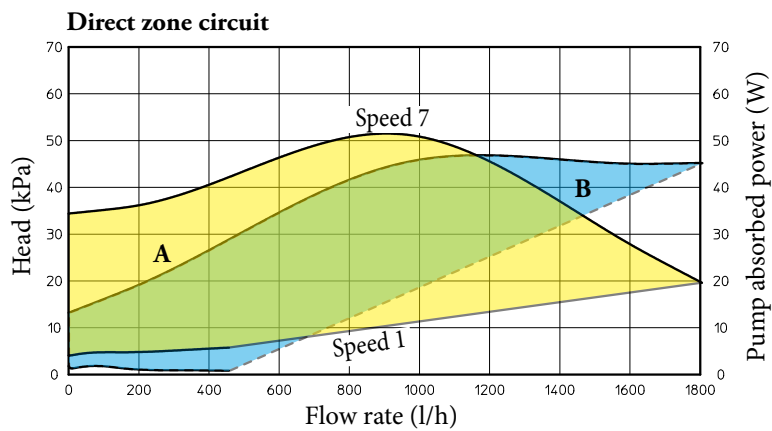
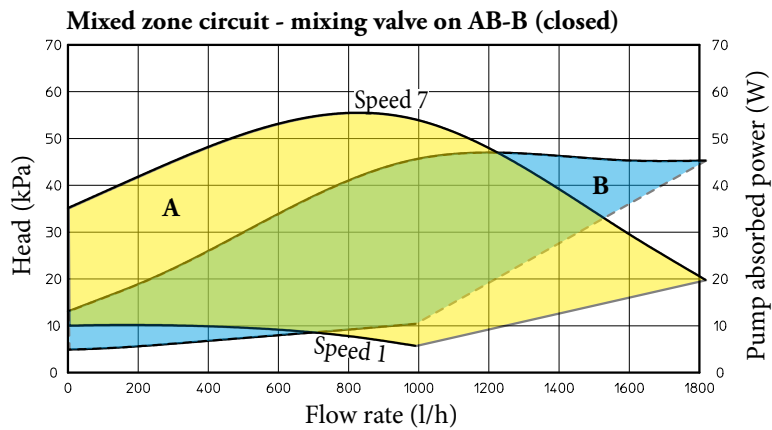
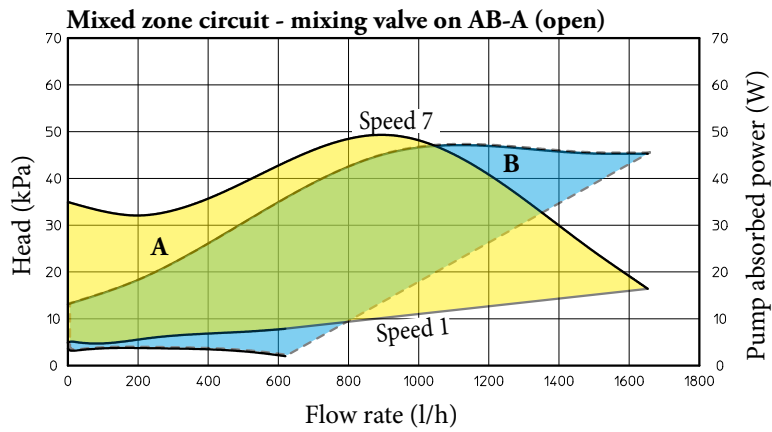

KEY:

A = Head available at speed 1 ÷ 7

B = Power absorbed by the system pump (dotted area)

EEI ≤ 0.20



The System manager (optional) is to be used mainly when wanting to couple an integrative boiler to MAGIS PRO V2. It is an electronic controller with microprocessor, realised with the objective of being a "unique manager" for integrated systems. Thanks to this innovative supervisor, it is possible to establish and activate the most convenient heat source depending on functional, environmental and "economic" parameters.

In fact, to control everything, the System manager must acquire the data relative to the external temperature and the system flow temperature (relative to the pre-set climatic curve), after having configured the fuel cost parameter (e.g. methane gas) and that of the electric energy.

Designed to enhance climatic comfort, it allows you to set different climatic curves for each zone, both for hot and cold. The user interface is made up from an LCD with matrix and a 6-key membrane keyboard. Installation takes place on a guide for electric components from control board.

27.1

TECHNICAL FEATURES

Using the system manager (integrated with the relative expansion kits) it is possible to control:

- MAGIS PRO V2;
- Immergas boiler;
- storage tank for D.H.W. production (the D.H.W. temperature is managed by the NTC probe);
- up to 2 solar circulation units for systems with manifolds arranged on different slopes;
- temperature probes (NTC - PT1000);
- on-off request dry contact;
- integrative electric resistance for DHW;
- the integrative electric resistance for the heating system is inserted in the MAGIS PRO V2 (hydronic module) and is directly controlled from the MAGIS PRO V2 electronics;
- variable flow temperature of the heat pump and the boiler (using the required models), depending on the external temperature (a climatic curve is pre-selected);
- 8 expansion boards for the management of the air conditioning system the maximum number of manageable zones is 8, to which 2 expansions can be added for special functions (expansions with address 4 and 5). For each single zone, it is possible to decide whether it is a mixed zone, a direct zone, or a direct zone with water temperature probe (thus allowing the correction of the outlet temperature from the generator also according to the flow temperature detected on the direct zones, useful if upstream there is a hydraulic manifold in which mixing with the system return takes place);
- 2 expansion boards for the additional functions, namely:
 - hot/cold switch-over on distinct systems (for example systems with radiant panel heating and fan-coil cooling);
 - recirculation pump management for DHW;

- acquisition of a signal from a system that generates electrical energy (e.g. photovoltaic system);

- as far as temperature/humidity control devices are concerned, a maximum of 4 Zone Panels/Controls can be associated only in zones 1-3 and HT (high temperature) zone. The Temperature/Humidity Sensor Kit can be used instead in all zones 1-8; another set-up is for room thermostats and on-off humidistats;
- up to 8 dehumidifiers.

On the other hand, in terms of the main settings that can/must be carried out, the System Manager allows you to acquire or programme:

- external temperature;
- system flow temperature;
- storage tank temperature (even through 2-3 probes, 1 of which refers to the solar-heated part of the boiler);
- by means of self-diagnosis, detection and display of error codes in the event of anomalies;
- date and time;
- differentiated selection and programming for each individual zone;
- programming the time periods for DHW production;
- anti-legionella program (in a system where there is a boiler or integrative resistance on the storage tank, in addition to the Heat pump);
- cost of combustion (Methane or LPG);
- cost of the electric energy;
- management of the heat/cooling sources.

• **SYSTEM MANAGER**

code 3.021522

MAGIS PRO V2

27.2

DESCRIPTION AND CONTROLS OF SPECIAL FUNCTIONS

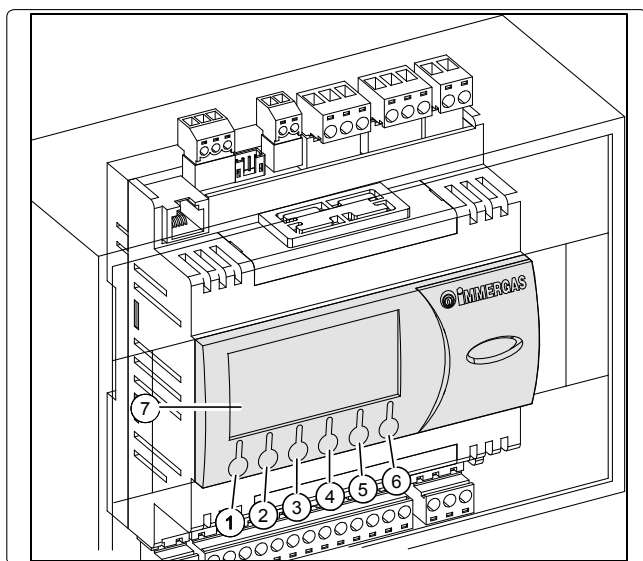

This **button (1)** allows you to change the operating mode of the system, specifically: Summer (only DHW and solar heating), Summer with cooling, Winter, Party (all zones are set in comfort mode), Standby (all requests are disabled: room antifreeze protection < 5°C only remains active, if Immergas room probe is installed). This **button (2)** allows you to access the submenus: Selection, Programming, Info, Alarms log, Assistance. This **button (3)** allows you to move back from a current menu to the previous one. These **buttons (4 and 5)** allow you to scroll through the menus on the screen cyclically or to increase or decrease the value of the various parameters. The **button (6)** enables you to change the displayed data. DISPLAY (7) description:

- winter - room central heating and DHW production functions are enabled;
- summer - DHW production only is enabled;
- comfort temperature is active;
- operating with automatic program;
- operating with manual program;
- operating with holiday timer program;
- operation with energy savings programme;
- symbol indicating anomaly;
- room central heating request in progress;
- request for DHW in progress;
- DHW heating and cooling program;
- operating in "Party" mode;
- request to heat or cool room;
- solar panel operation in progress;
- system in Stand-by;
- request for room cooling in progress;
- dehumidifier with cooled air;
- dehumidifier with neutral air;

The system Manager is equipped with several important functions and application options:

- Set climatic curves for each zone, both for hot and cold; maximum temperature of 85 °C, which can be selected for all zones;
- Identify each zone independently: only hot, hot/cold, hot/cold with dehumidifier and dew point calculation, cold only, cold only with dehumidifier and dew point calculation. The said dew point calculation function can also be enabled/disabled if dehumidifier management is disabled (e.g. with another dehumidifier system managed independently);
- Set the Tminimum integration (cut off) or COP calculation to use the heat pump;
- Optimise the flow temperature to the system by means of probes situated on the secondary booster circuit (e.g. with a hydraulic manifold);
- In the event of boiler integration, it is also possible to keep MAGIS PRO V2 permanently active if COP is advantageous. The Manager must be connected to the boiler via the external probe clamps (range models VICTRIX TT ErP, VICTRIX kW TT, VICTRIX MAIOR TT, VICTRIX EXA, VICTRIX SUPERIOR ErP and all models with SUPERIOR electronics);
- DHW production storage tank management via the heat pump as opposed to the solar system (MAGIS PRO V2 connected to the lower coil, boiler connected to the upper coil), in order to obtain renewable source coverage on DHW;
- Option to have remote-domotic management on the Manager. 3 digital inputs are used on expansion address "5", which, according to their status (open/closed), determine the operation mode. Contact "domotic" management is executed using the following options:
 - Standby (inputs ID1=0 ID2=0 ID3=0);
 - Winter (inputs ID1=1 ID2=0 ID3=0);
 - Summer (inputs ID1=1 ID2=1 ID3=0);
 - Cooling (inputs ID1=0 ID2=0 ID3=1);
 - Party (inputs ID1=1 ID2=0 ID3=1);
- Digital output 4 regarding expansion address "5" is enabled in the event of a system anomaly (for an error message to be sent to the domotic system);
- Input on expansion address "5" to force activation of MAGIS PRO V2 with the FV system which generates electricity. By using an inverter/electronic device that supplies a signal when FV production exceeds a set value, a contact closes on expansion address "5", which:
 - Immediately brings the DHW storage tank to 55 °C, disabling any programmed DHW time bands;
 - The minimum COP functional convenience is reset and Tminimum integration brought to -15 °C, thus removing integration from the boiler; the only thing that remains active is the maximum time for the system to be fully operational, beyond which the boiler is activated in order to guarantee climatic comfort;
 - If a puffer system is configured in the menu, it is heated up to 55 °C, even without request from the system; also in this case, the only thing to remain active is the maximum time for the system to be fully operational.
- Input on expansion address "4" to disable the generators when a thermal chimney operates.

28 ZONE REMOTE PANEL (WITH SYSTEM MANAGER)



It is an electronic device equipped with a back-lit display to control and adjust the room's temperature and humidity. Connection to the System manager occurs via two BUS cables. It programs the relative room heat adjustment. It can be applied to the wall using the supplied screws and plugs. The kit is powered at 24 V (directly from the Manager).

• **OPTIONAL** code 3.030863

29 ZONE REMOTE CONTROL KIT (WITH SYSTEM MANAGER)



It is an electronic device equipped with a back-lit display to control and adjust the room's temperature and humidity. Connection to the System manager occurs via two BUS cables. It programs the relative room heat adjustment. It can be applied to the wall using the supplied screws and plugs. The kit must be powered at 230 Vac (externally).

• **OPTIONAL** code 3.023364

30 TEMPERATURE/HUMIDITY SENSOR KIT (WITH SYSTEM MANAGER)



It is a room temperature and humidity probe, to be applied to the wall. Differently to the zone remote control kit, in this case, the settings of all room parameters take place on the System Manager. The kit must be connected directly to the expansion board for zone management. The kit is powered at 24 V.

• **OPTIONAL** code 3.021524

31 SYSTEM CONTROLLER EXPANSION KIT (WITH SYSTEM MANAGER)



This component must be powered at 24 Vac and is mainly used for system zone management; in particular n°1 expansion kit must be used for each zone. The expansion kit manages pump, mixing valve and the dehumidifier of the same zone, acquiring the room request (temperature and humidity) for a determined zone. The following can be connected to this kit:
 - the room temperature and humidity sensor;
 - an on-off type request contact.
 Installation takes place on a DIN guide for electric components from control board. **This board is envisioned as per standard in the 2 kits for zone systems** (see the following page).

• **OPTIONAL** code 3.021547

MAGIS PRO V2

32

DISTRIBUTION KIT TO THE SYSTEM (WITH SYSTEM MANAGER)



Two pre-packaged systems called: "2 mixed zones kit" and "2 mixed zones and 1 direct zone kit". They are comprised of 2 separate hydraulic manifolds (flow/return) + by-pass, thermometers to read the temperatures, motorised mixing valves, low energy consumption electro pumps and expansion boards for electric management.

The pumps included in the kit are distinguished for being very elastic, also thanks to the 7 operating curves that can be pre-set. All parts are already assembled and ready for operation exclusively in combination with the System Manager. With the aid of the expansions the 2 kits are governed by the System Manager during the central heating and cooling phases.

Acquisition of the outdoor temperature from system Manager enables you to select independent flow temperature curves for each of the 2 or 3 zones of the system (both with C.H. and cooling).

Inserting these kits into the technological system enhance overall comfort and energy savings.

32.1

DIMENSIONS AND CONNECTIONS

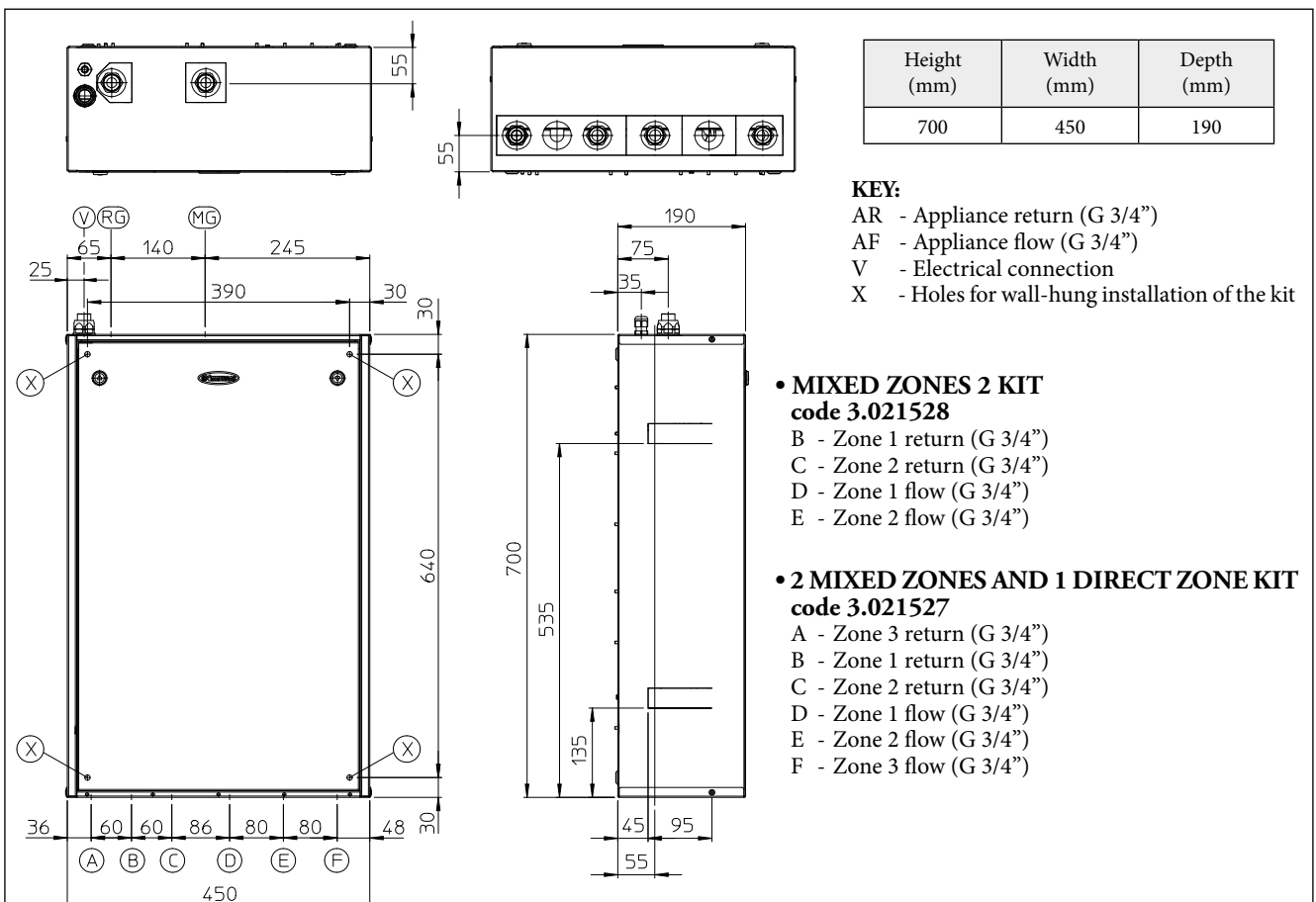

32.2

TECHNICAL DATA

		Mixed zones 2 kit	2 mixed zones and 1 direct zone kit
Maximum nominal pressure	bar	3	3
Maximum operating pressure	°C	90	90
Low temperature circuit minimum set point regulation temperature	°C	25	25
Low temperature circuit maximum set point regulation temperature	°C	50 ÷ 80	50 ÷ 80
Water content in device	litres	1.5	1.9
Total head available in non-mixed zone with 1000 l/h flow rate (max.)	kPa (m H ₂ O)	--	43.18 (4.40)
Total head available in mixed zone (mixing valve closed) with 1000 l/h flow rate (max.)	kPa (m H ₂ O)	42.07 (4.29)	42.07 (4.29)
Empty device weight	kg	21.1	23.1
Full device weight	kg	22.6	25.0
Electrical connection	V/Hz	230/50	230/50
Maximum input	A	0.9	1.2
Installed electric power	W	105	150
Power in Stand-by	W	9.5	9.5
Electric plant protection	-	IPX4D	IPX4D
Hydraulic side generator - kit maximum distance	m	15	15

32.3

CIRCULATION PUMP SETTINGS AND CONFIGURATIONS

The kits are supplied with circulating pumps fitted with speed regulator. These settings are suitable for most systems.

For proper operation one must select the most suitable type of operation for the system and select a speed between 2 and 7.

- **Program constant head (ΔP C)**. The circulator pump maintains the pressure level (head) constant as the system heat demand decreases (flow rate reduction). With these settings, the circulator pump is suitable for all floor systems where all the circuits must be balanced for the same drop in head. One can select the operating level from minimum to maximum by turning the selector switch clockwise in the relative power scale (refer to the drawing below).

- **Program proportional head (ΔP V)**. This allows the pressure level (head) to be proportionally reduced as the system heat demand decreases (flow rate reduction). Thanks to this function, the electric power consumption of the circulator pump is reduced further: the energy (power) used by the pump decreases according to the pressure level and flow rate. With this setting, the pump guarantees optimal performance in most heating systems, proving particularly suitable in single-pipe and two-pipe installations. Any noise originating from the water flow in the pipes, valves and radiators is eliminated by reducing the head. One can select the operating level from minimum to maximum by turning the selector switch anticlockwise on the relative power scale (refer to the drawing below).

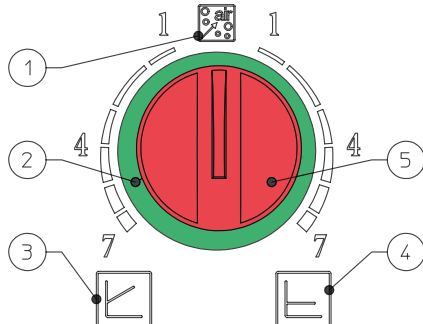

KEY:

- 1 - Automatic vent mode operation
- 2 - Light ring to indicate the operating status
- 3 - Proportional head operation
- 4 - Constant head operation
- 5 - Operating mode selector switch

MAGIS PRO V2

32.4 GRAPHS OF CIRCULATION PUMP FLOW RATE-ABSORPTION-HEAD

The kit contains an electronic low consumption circulation pump, whose flow rate/head features are shown in the graph below.

All pumps in the kit are suitable for operation with heat and cold carrying fluid.

ZONE MIXED WITH A CLOSED MIXING VALVE AND BY PASS COCK OPEN

WILO YONOS PARA RS 15-7 RKA CM 130

Constant head ($\Delta P C$).

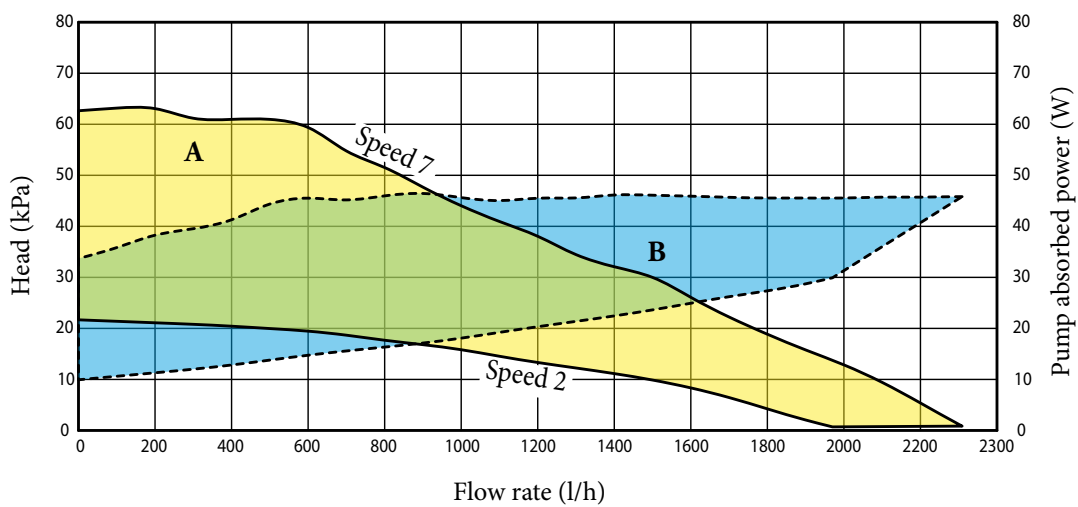

Proportional head ($\Delta P V$).

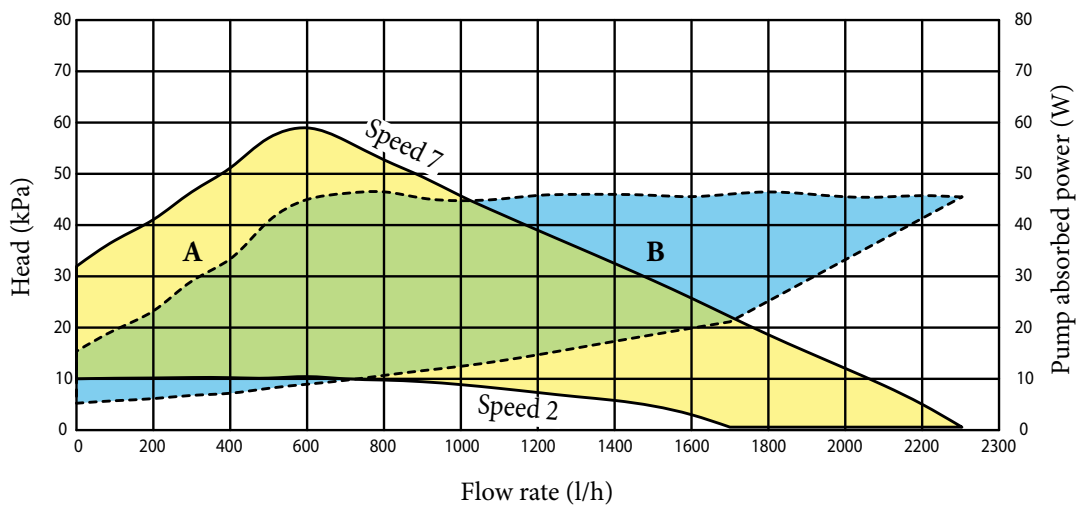

EEI \leq 0.20

KEY:

A = Head available at speed 2 ÷ 7

B = Power absorbed by the system pump (dotted area)

NOTE: In case of closed by-pass cock, the available head also depends on the upstream circuit of the kit. Starting from the available head shown in the figure, to determine the available pump head it is necessary to subtract the head losses of the circuit upstream of the kit.

32.5 GRAPHS OF CIRCULATION PUMP FLOW RATE-ABSORPTION-HEAD

The kit contains an electronic low consumption circulation pump, whose flow rate/head features are shown in the graph below.

All pumps in the kit are suitable for operation with heat and cold carrying fluid.

ZONE MIXED WITH AN CLOSED MIXING VALVE AND DIRECT ZONE AND BY PASS COCK OPEN

WILO YONOS PARA RS 15-7 RKA CM 130

Constant head ($\Delta P C$).

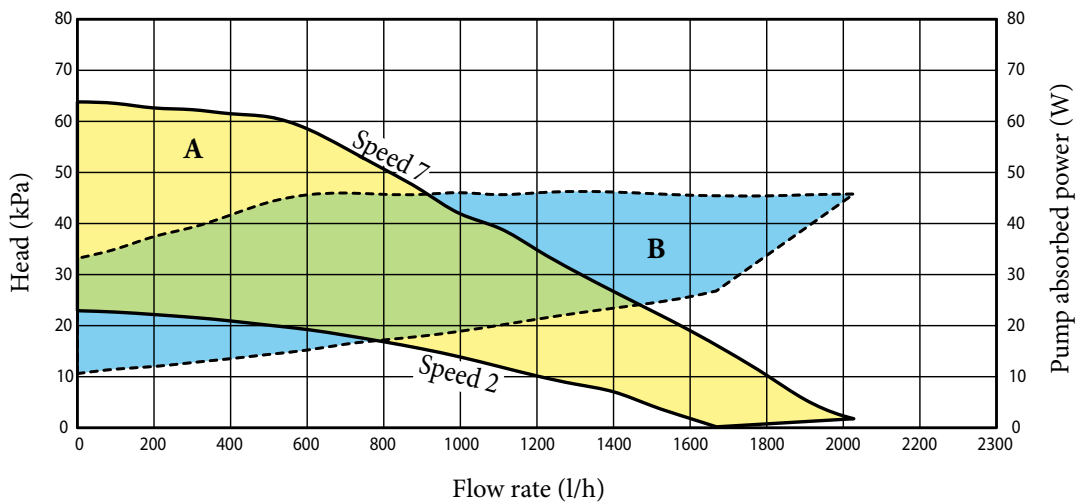

Proportional head ($\Delta P V$).

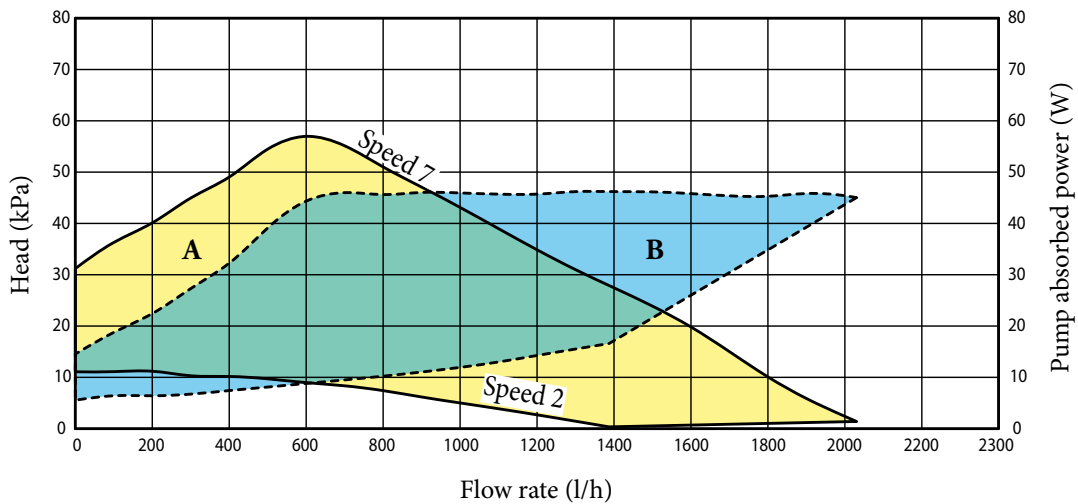

EEI ≤ 0.20

KEY:

A = Head available at speed 2 ÷ 7

B = Power absorbed by the system pump (dotted area)

NOTE: In case of closed by-pass cock, the available head also depends on the upstream circuit of the kit. Starting from the available head shown in the figure, to determine the available pump head it is necessary to subtract the head losses of the circuit upstream of the kit.

MAGIS PRO V2

33

DEHUMIDIFIER



Designed to be coupled to cooling plants with radiant panels, the dehumidifier allows to keep the percentage of relative humidity in the room within the comfort values, preventing the possible formation of condensate on the walls.

The dehumidifier, which is designed to be installed vertically on the wall (recessed), has pre- and post-cooling coils.

These components allow excellent control of the air temperature and humidity.

However, it can function without the aid of pre and post cooling water coils, thus allowing to dehumidify when the cooling system is off, typical of mid-season.

In compliance with European Directives, it has EC declaration of conformity.

Dehumidification can take place:

- with **neutral air**: without variation of the air temperature, dehumidifies internal rooms;
- with **cooled air**: contributes to cooling the rooms, as well as reducing the internal relative humidity.

This operation can only be obtained with the System manager and its expansions, to couple the dehumidifier directly to MAGIS PRO V2 (in each zone, there is a dehumidifier activation single contact), see the paragraph "MAGIS PRO V2 management electronic functions".

33.1

DIMENSIONS AND CONNECTIONS

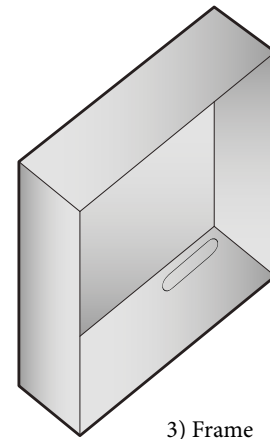
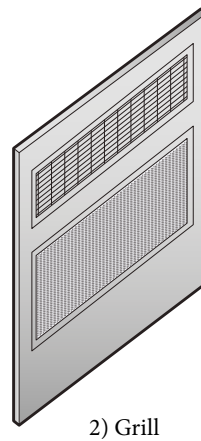
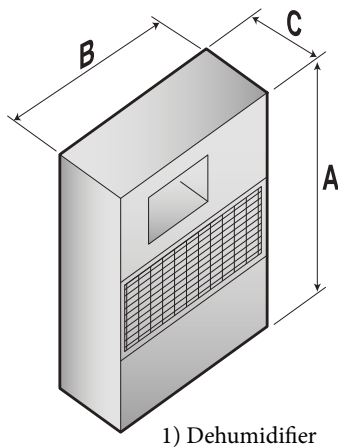

Model	A (mm)	B (mm)	C (mm)
1	680	545	221
2	750	660	20
3	703	605	228

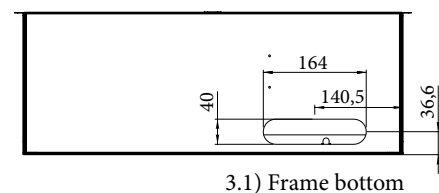

• **DEHUMIDIFIER** code 3.021529
(frame and grid to be purchased separately)

Connect the F-R (female) 1/2" fittings of the dehumidifier to the cooling system, using the measurements in fig. 3.1

33.2

OPERATING PRINCIPLE

The **humid air** is taken from the room through the fan (7) and made to pass through the filter (1) and the pre-cooling water coil (2), where the air itself is cooled and taken to a condition near to the saturation curve. It then passes through the evaporating coil (3) where air is further cooled and dehumidified

LEGENDA:

- 1 - Air filter
- 2 - Pre-cooling coil
- 3 - Evaporator
- 4 - Compressor
- 5 - Condenser
- 6 - Post-cooling coil
- 7 - Fan
- 8 - Throttle valve
- 9 - Dryer filter
- 10 - Cut-off valve

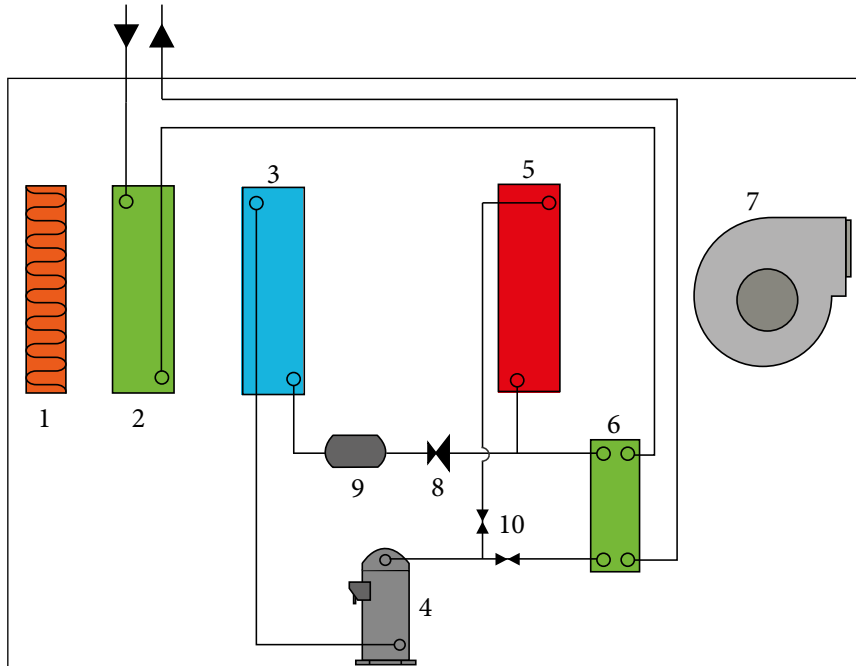

Dehumidification mode with neutral air

The cooling circuit works by partially condensing in water through the heat exchanger (6) and partially in air through the heat exchanger (5); accordingly air post-heating is performed and this air is sent into the room in thermically neutral conditions

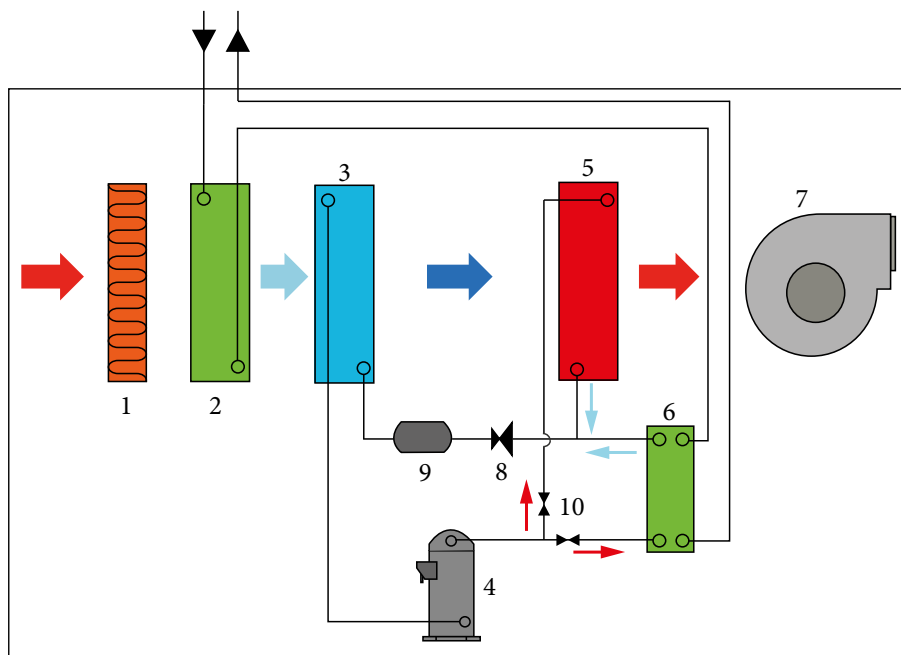

MAGIS PRO V2

Dehumidification mode with cooled air

In this case, the cooling circuit performs 100% of condensation in water via the heat exchanger (6). The condenser (5) is cut-off via the valve (10) and the air sent into the room is the same – cooled and dehumidified – at evaporator outlet (3)

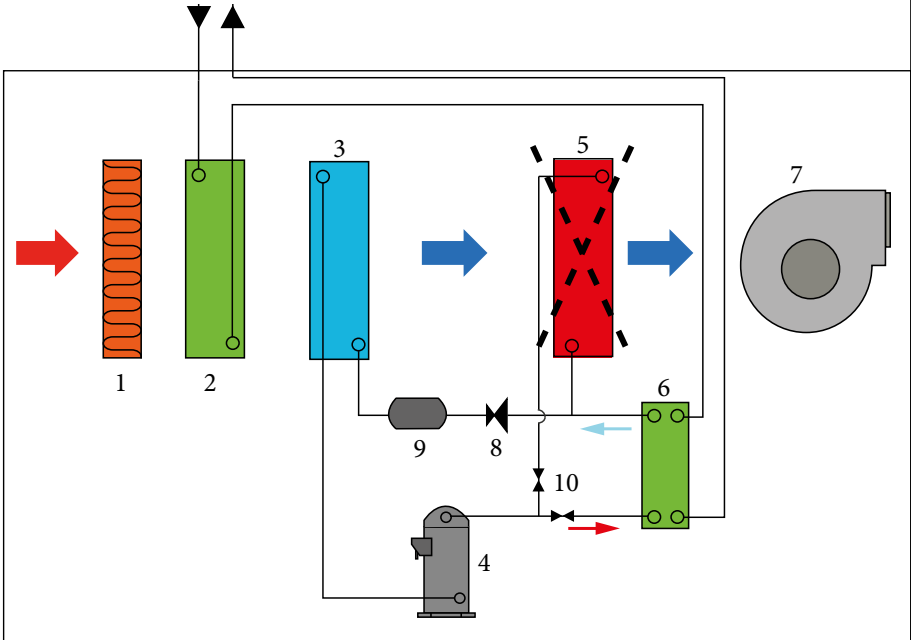

33.3 DEHUMIDIFIER LAYOUT AND WIRING DIAGRAMS (WITH SYSTEM MANAGER AND EXPANSION)

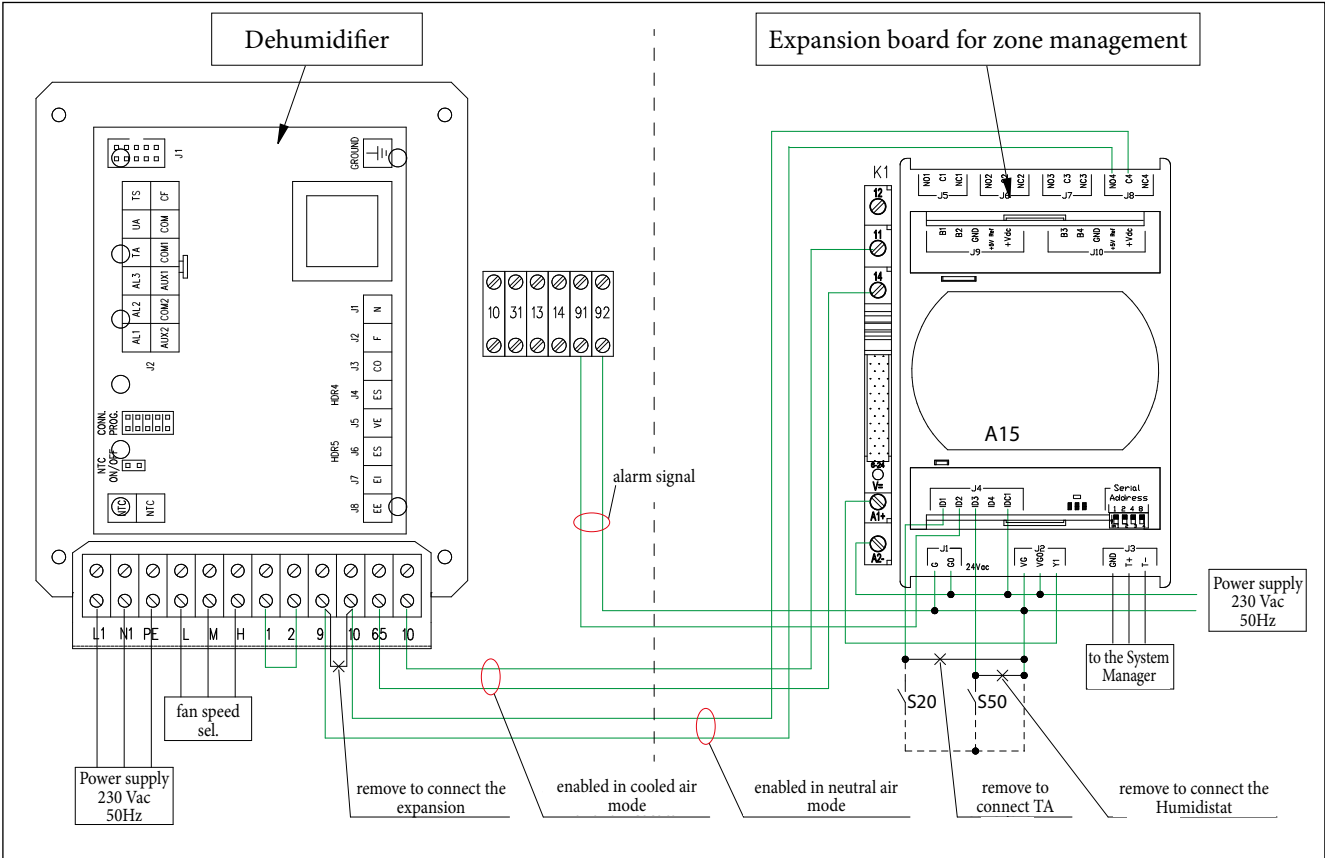

33.4 TECHNICAL DATA

Coolant		R134a
Humidity removed in neutral air condition ⁽¹⁾	litres/24h	20.1
Cooling capacity ⁽¹⁾	W	1250
Nominal water input	l/h	150
Head losses	kPa	7.8
Water supply temperature operating field	°C	15 - 45
work humidity field	%	40 - 90
Air flow rate	m ³ /h	250
Fan useful static head (maximum speed)	Pa	43
Sound pressure ⁽³⁾	dB(A)	35
Sound power	dB(A)	43
Power absorbed ⁽¹⁾	W	340
Power supply	V/Ph/Hz	230/1~/50
Maximum power absorbed ⁽²⁾	W	450
Nominal current absorbed ⁽¹⁾	A	2.5
Maximum current absorbed ⁽²⁾	A	2.8
Hydraulic F-R connections		1/2" F
Weight	kg	38

The data given refer to the following conditions:

¹⁾ Room temperature 26 °C; relative humidity 65% with coil inlet water temperature of 15 °C.

²⁾ Room temperature 35 °C; relative humidity 80%.

³⁾ Sound pressure level measured in free field at 1 m from the machine, in compliance with UNI EN ISO 3746/97

33.5 HEAD LOSS OF THE HYDRAULIC CIRCUIT

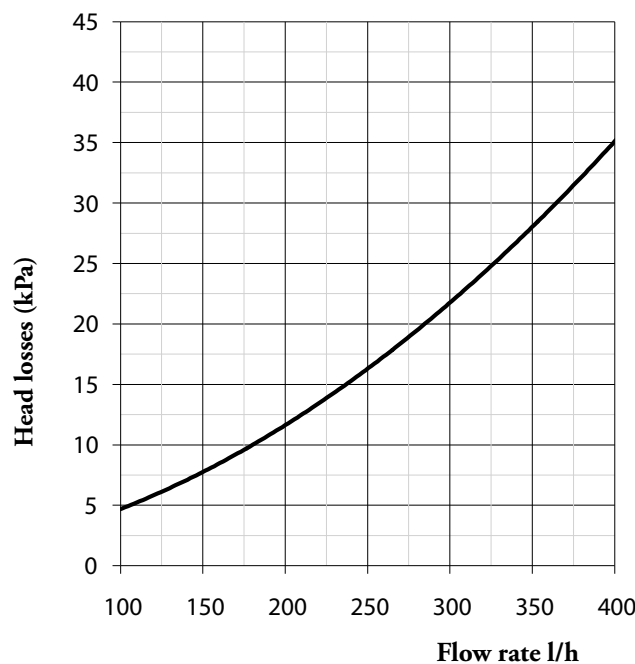

MAGIS PRO V2

34 INTRODUCTION WITH COMMENTARY TO THE DIAGRAMS: MAIN APPLICATIONS

35-35.1 Diagram with MAGIS PRO V2 and kit 2 zones for coupling to MAGIS PRO +

Integrative resistance for heat system

Description of winter functioning:

- **CH phase active:** 1 or more room sensors activate consent in the winter phase: in this diagram MAGIS PRO V2 is integrated through the 3 kW electric resistance (optional), to be inserted in the hydronic module. The logic plans to activate the resistance if I do not reach the temperature set within the maximum time, or below a certain outdoor temperature (settable) I can immediately activate the resistance.

- **D.H.W. phase:** The MAGIS PRO V2 electronics constantly monitor the DHW temperature set (probe located in the storage tank), activating MAGIS PRO V2.

N.B.: Any solar system must be managed by a solar control unit, to be purchased separately.

36-36.1 Diagram with MAGIS PRO V2 (air conditioning only) + boiler PLUS + kit system distribution + solar heating for DHW + System manager

Description of winter functioning:

- **C.H. mode active:** 1 or more remote panels activate winter mode consent, the system Manager, according to the outdoor temperature detected and the room temperature set above the pre-set climatic curve, activates MAGIS PRO V2 or the boiler according to the COP calculated (if > the minimum economical convenience value - use of MAGIS PRO V2 is approved), or according to T_{minimum} integration (cut off) set in the System Manager.

Remember that also times for making the system operational can vary the boiler insertion mode.

- **Domestic hot water phase:** this system was designed to privilege DHW operation of the boiler only, obviously in addition to the solar heating system (governed by the System Manager). During the summer cooling phase, the inversion of the MAGIS PRO V2 functioning cycle is also prevented (from chiller to heat pump).

35 HYDRAULIC DIAGRAM: MAGIS PRO V2 + KIT 2 ZONES (1 DIRECT AND 1 MIXED) + INTEGRATIVE RESISTANCE FOR HEAT SYSTEM

- A - Condensing unit supply voltage
- B - Hydronic module supply voltage
- C - Heating system integrative electric resistance supply voltage

- 1 - AUDAX PRO V2 condensing unit (inclusive of outdoor probe)
- 2 - Hydronic module
- 3 - Heating system integrative electric resistance (optional)
- 4 - INOXSTOR V2 storage tank unit
- 5 - Storage tank probe
- 6 - DHW inlet safety unit (not supplied)
- 7 - Kit 2 zones (for coupling to MAGIS PRO)
- 8 - Inertial storage (to size)
- 9 - Thermostatic mixing valve
- 10 - Remote zone control

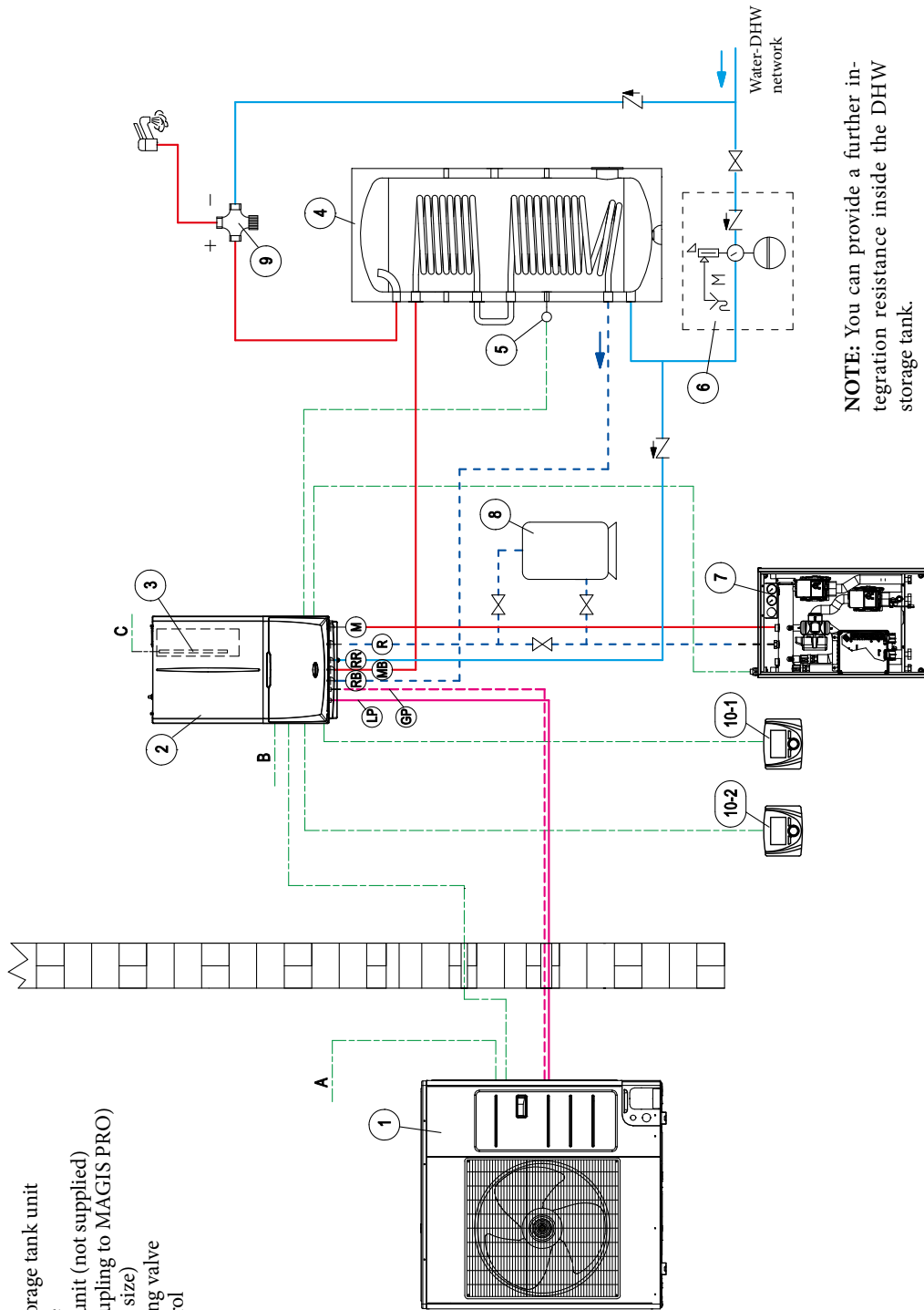

NOTE: You can provide a further integration resistance inside the DHW storage tank.

NOTE: this diagram is an example. It is also required to convey the heat pump's condensate drain. In order to guarantee proper Heat Pump operation, each system must consider inserting a bypass to guarantee a minimum flow rate of 500 l/h.

MAGIS PRO V2

35.1 WIRING DIAGRAM: MAGIS PRO V2 + KIT 2 ZONES (1 DIRECT AND 1 MIXED) + INTEGRATIVE RESISTANCE FOR HEAT SYSTEM

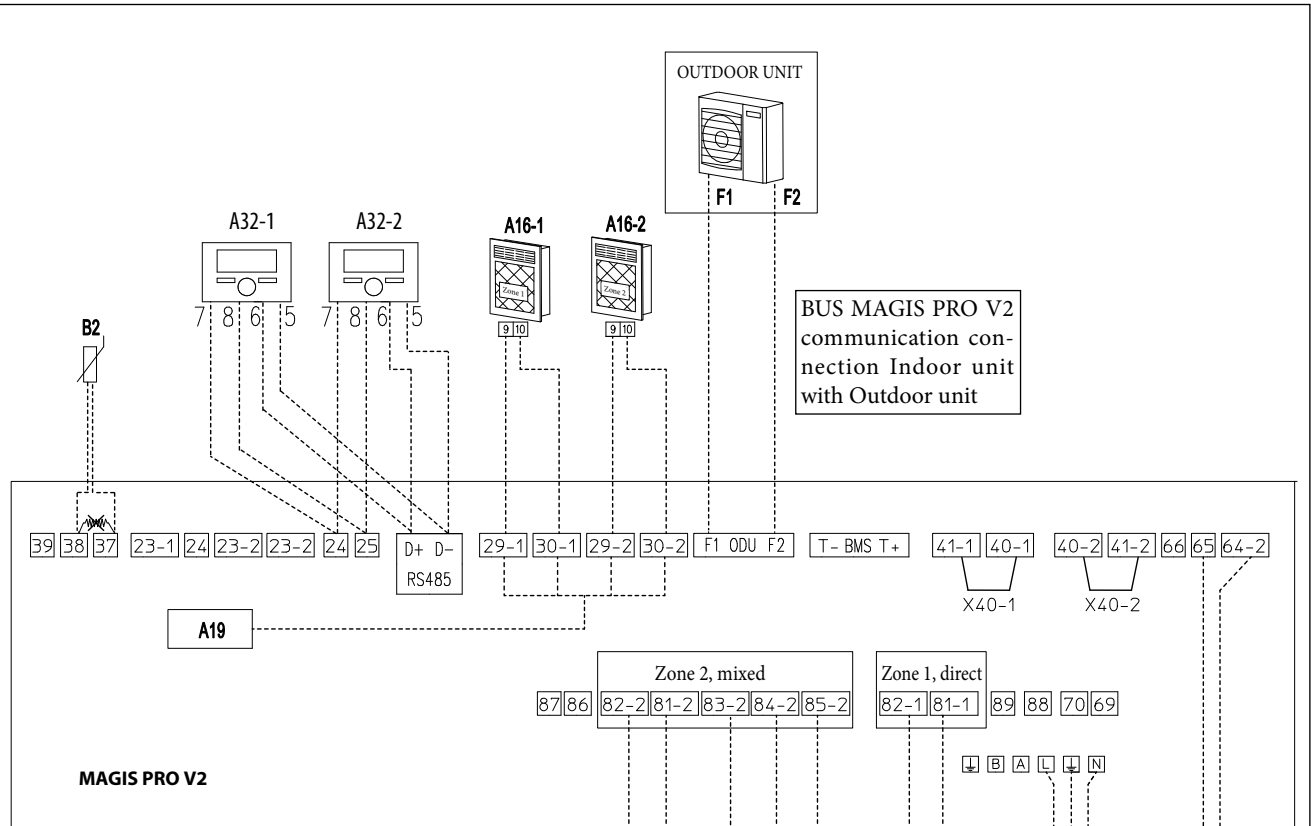

KEY:

- A32-1 - Remote zone 1 control
- A32-2 - Remote zone 2 control
- A16-1 - Dehumidifier zone 1
- A16-2 - Dehumidifier zone 2
- A19 - 2-relay board (optional)
- B2 - Storage tank temperature probe
- B3-2 - Zone 2 mixed flow probe
- M10-1 - Zone 1 circulator pump
- M10-2 - Zone 2 circulator pump
- M31-2 - Zone 2 mixing valve
- F1/F2 (ODU) - AUDAX PRO V2 communication bus

NOTE: please note that, in a setting without room thermostats, in order to meet the requirements coming from Zone remote panel, it is necessary to keep the jumper [X40-1] on clamps 40-1 and 41-1 and jumper [X40-2] clamps 40-2 and 41-2.

NOTE: To control the 2 dehumidifiers provide the 2-relay board kit (A19) for dehumidifiers management (optional) code 3.026302.

When using the ModBus temperature and humidity sensor kit (code 3.030992), in order to make temperature requests it is necessary to match a room thermostat in the zone as it is not possible to set the room set directly from the control panel.

To electrically connect the CH electric resistance, see the corresponding instruction sheet.

You can provide a further integration resistance inside the DHW storage tank.

36 HYDRAULIC DIAGRAM: MAGIS PRO V2 (AIR CONDITIONING ONLY) + BOILER PLUS + SYSTEM DISTRIBUTION KIT + SOLAR HEATING FOR DHW + SYSTEM MANAGER

- KEY:**
- 1 - AUDAX PRO V2 condensing unit (inclusive of outdoor probe)
 - 2 - Hydronic module
 - 3 - VICTRIX kW TT PLUS Boiler
 - 4 - System manager
 - 5 - Solar ErP circulation unit with safety valve
 - 6 - Solar expansion vessel
 - 7 - Flat solar collectors
 - 8 - Solar collector probe PT1000 code 3.019374
 - 9 - Thermostatic mixing valve
 - 10 - INOXSTOR V2 storage tank unit
 - 11 - Storage tank unit upper part NTC probe
 - 12 - NTC probe for storage tank unit bottom part
 - 13 - DHW inlet safety unit (not supplied)

- 14 - Kit 2 mixed zones and 1 direct zone (for coupling to System manager)
- 15 - Remote zone control code 3.030863
- 16 - Room chrono-thermostat
- 17 - Inertial storage (to size)

- A - Condensing unit supply voltage
- B - Hydronic module supply voltage
- C - Boiler supply voltage
- D - System manager supply voltage
- E - 2 Mixed zones and 1 direct zone kit supply voltage

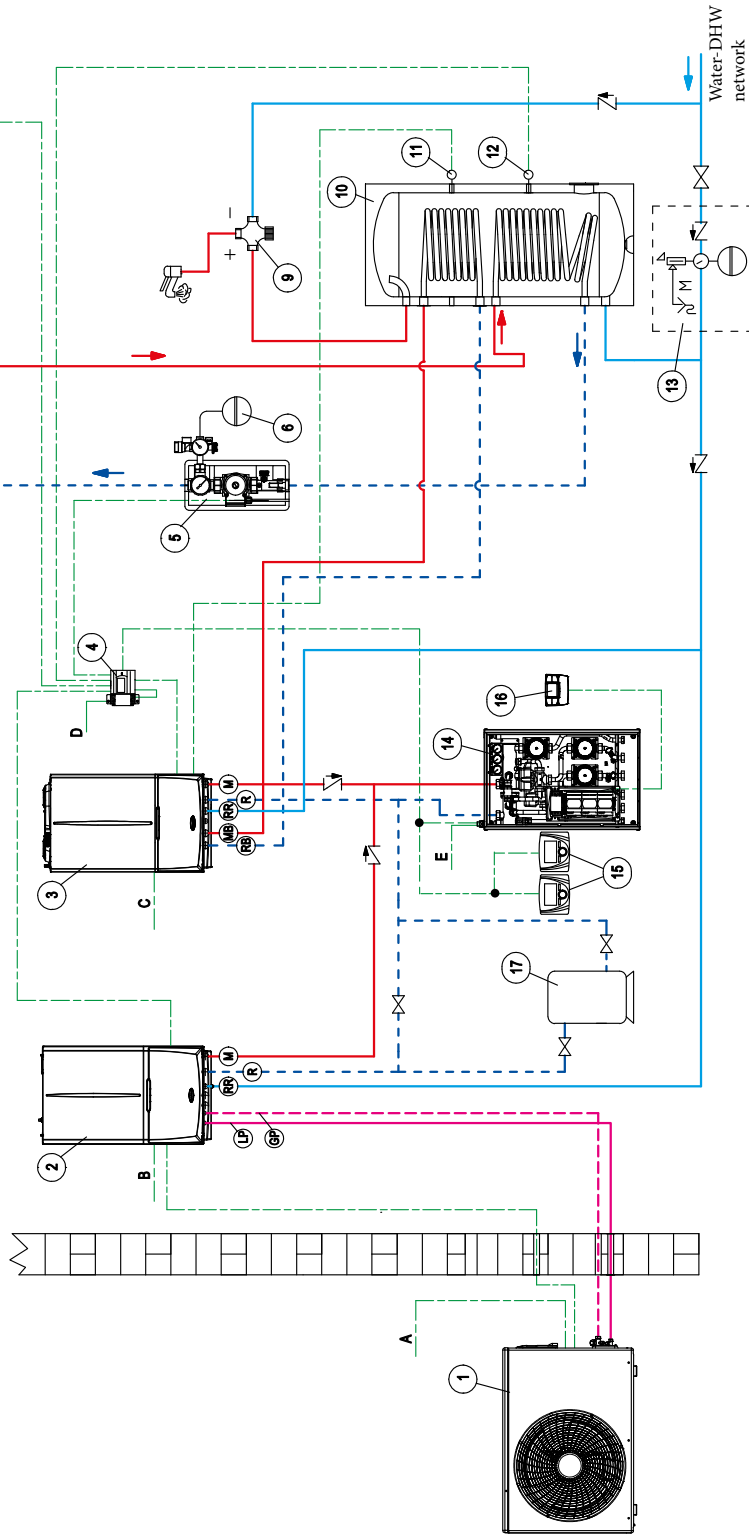

NOTE: this diagram is an example. It is also required to convey the condensate drain of the heat pump and boiler. In order to guarantee proper Heat Pump operation, each system must consider inserting a bypass to guarantee a minimum flow rate of 500 l/h. In this diagram, the bypass is already installed in the zones kit (14).

MAGIS PRO V2

36.1 WIRING DIAGRAM: MAGIS PRO V2 (AIR CONDITIONING ONLY) + BOILER PLUS + SYSTEM DISTRIBUTION KIT + SOLAR HEATING FOR DHW + System MANAGER

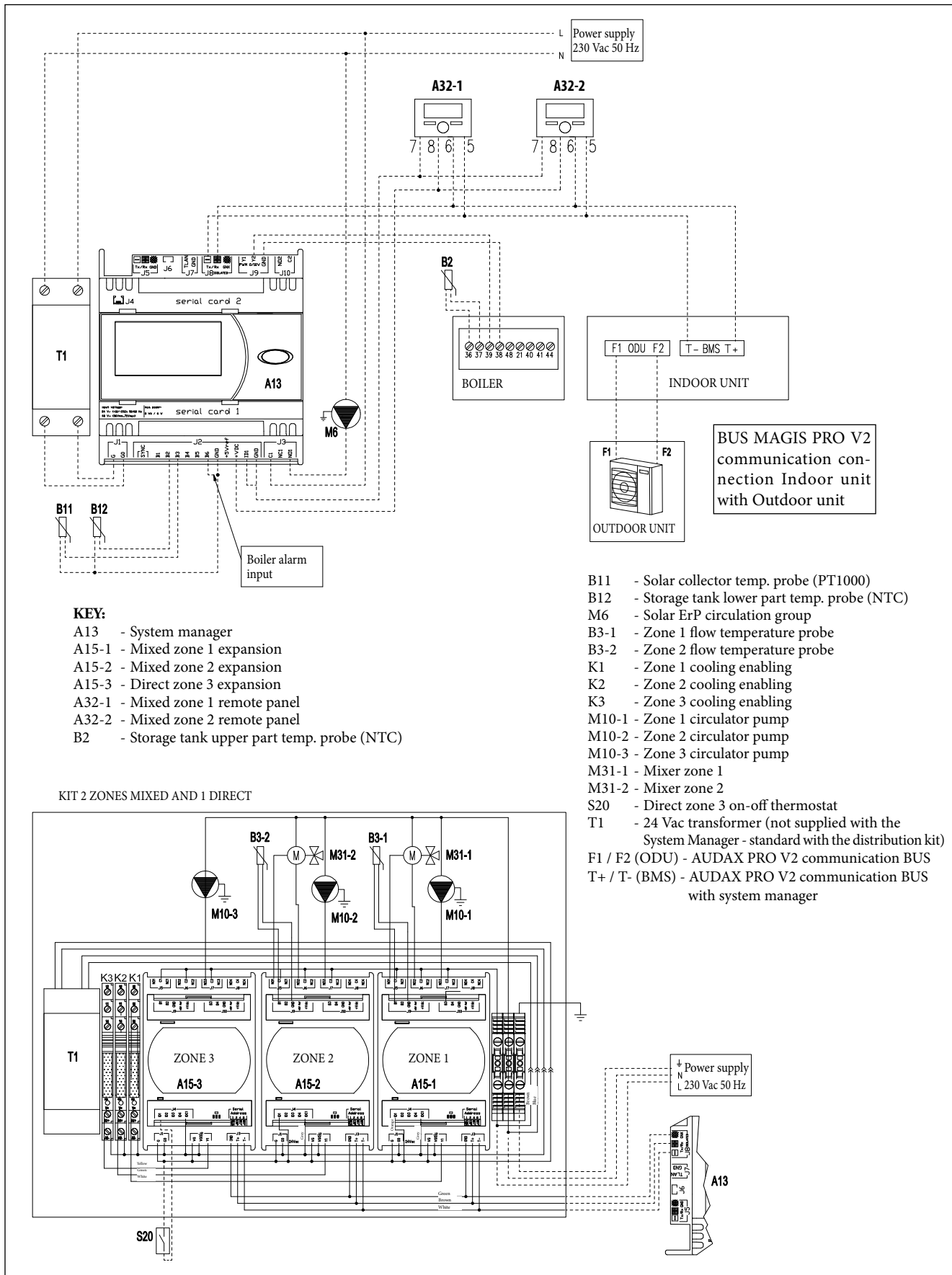

37 OPTIONAL FOR DIRECT COUPLING TO MAGIS PRO V2 (STAND ALONE)

TEMPERATURE CONTROL OPTIONALS	Code
Zone Remote panel - (device class V* or VI)	3.030863
Temperature and humidity sensor kit ModBus - (device class V or VI*) - to make temperature requests, it is necessary to couple a chrono-thermostat code 3.021622 or 3.021624	3.030992
CRONO 7 (Digital weekly chrono-thermostat) - (device class IV* or VII)	3.021622
CRONO 7 WIRELESS (device class IV* or VII)	3.021624
External probe - if the condensing unit is installed under unfavourable conditions (device class II* or VI or VII)	3.015266
Room hygrostat - (operates on the Dehumidifier according to the humidity detected in the room and according to what is set on the device)	3.023302
DOMINUS Interface kit (for remote control via App)	3.026273
OTHER OPTIONALS	Code
Distribution manifold kit for 1 direct and 1 mixed temperature zones for direct connection to MAGIS PRO (wall-hung or recessed for mixed systems)	3.026301
Three-way diverter valve kit to be used as diverter valve for heating/cooling switching	3.020632
3 kW integration electric resistance kit (to be inserted inside the hydronic module, 230 Vac power supply)	3.030991
Additional 2 kW resistance kit 200-300-500 INOXTOR and OMNISTORE	3.020861
Additional 5 kW resistance kit for 1000-1500 litre storage tanks	3.020862
Antifreeze protection kit -15 °C (for hydronic module protection)	3.017324
Dehumidifier kit - for recessed installation only	3.021529
Dehumidifier frame kit	3.022146
Dehumidifier grid kit	3.022147
2 relay board kit for MAGIS PRO V2 coupling (for dehumidifier control)	3.026302
Contact NTC probe kit for storage tank (can also be used to read the temperature of a possible Puffer)	3.019375
Configurable relay board kit (to manage 3rd ^{mixed} zones and other features)	3.015350
Low temperature safety kit	3.019229
Connection kit for R32 circuit (to allow easy connection of the cooling circuit also in case of pipes that arrive at the rear)	3.030883
Buffer tank 75 litres (can be installed wall-hung vertically or on floor)	3.027288
Bracket kit for wall mounting Buffer tank 75 litres (for wall-hung installation)	3.027290
Wall installation brackets kit for outdoor condensing unit	3.022154
Condensate antifreeze heating cable kit (for outdoor condensing unit)	3.027385

*Device class (REF. Communication of the European Commission 2014/C 207/02) with factory settings.

MAGIS PRO V2

38

OPTIONAL IN THE PRESENCE OF SYSTEM MANAGER

TEMPERATURE CONTROL OPTIONALS	Code
System manager kit - (device class V* or VIII)	3.021522
Zone Remote panel - (device class V* or VI)	3.030863
CRONO 7 (Digital weekly chrono-thermostat) - (device class IV* or VII)	3.021622
CRONO 7 WIRELESS - (device class IV* or VII)	3.021624
Zone Remote control kit - (device class V or VI*)	3.023364
Room hygrost - (operates on the Dehumidifier according to the humidity detected in the room and according to what is set on the device)	3.023302
Temperature and humidity sensor kit - (device class V or VI*)	3.021524
OTHER OPTIONALS	Code
Distribution manifold kit for 2 mixed temperature zone (wall-hung or recessed)	3.021528
Distribution manifold kit for 1 direct and 2 mixed temperature zone (wall-hung or recessed for mixed systems)	3.021527
System controller expansion kit (to manage zone or for auxiliaries)	3.021547
Three-way diverter valve kit to be used as diverter valve for heating/cooling switching	3.020632
Additional 2 kW resistance kit 200-300-500 INOXTOR and OMNISTORE	3.020861
Additional 5 kW resistance kit for 1000-1500 litre storage tanks	3.020862
Antifreeze protection kit -15 °C (for hydronic module protection)	3.017324
Dehumidifier kit - for recessed installation only	3.021529
Dehumidifier frame kit	3.022146
Dehumidifier grid kit	3.022147
Probe kit for solar collector temperature (coupled with a system manager)	3.019374
Contact NTC probe kit for storage tank (can also be used to read the flow temperature on the system zones)	3.019375
Relay kit to enable the DHW integrative resistance kit for boilers managed with an on-off contact or for dehumidifier cooling request (EMR 12 Vdc)	3.023945
Low temperature safety kit for low temperature systems and system distribution kit	3.013794
Connection kit for R 32 circuit (to allow easy connection of the cooling circuit also in case of pipes that arrive at the rear)	3.030883
Buffer tank 75 litres (can be installed wall-hung vertically or on floor)	3.027288
Bracket kit for wall mounting Buffer tank 75 litres (for wall-hung installation)	3.027290
Wall installation brackets kit for outdoor condensing unit	3.022154
Condensate antifreeze heating cable kit (for outdoor condensing unit)	3.027385

*Device class (REF. Communication of the European Commission 2014/C 207/02) with factory settings.

DECLARATION OF CONFORMITY OF THE PRODUCT

**To download the updated declaration of conformity of the product, please refer to the
IMMERGAS website:
www.immergas.com**

MAGIS PRO V2

APPENDIX A): TRIO V2 SYSTEM PRO WITH MAGIS PRO V2

39 TRIO V2 WITH SYSTEM PRO (MAGIS PRO V2 + POSSIBLE RESISTANCES)



39.1 DESCRIPTION SYSTEM PRO WITH TRIO V2

The System Pro represents a split "no gas" solution obtained by installing the MAGIS PRO V2 hydronic module inside the SOLAR CONTAINER or the DOMUS CONTAINER, with a cooling connection to the outdoor condensing unit. MAGIS PRO V2 caters for all services, with the possible integration of electric resistances: in particular, the Integrative electric resistance kit for 3 kW system (code 3.030991) is inserted in the hydronic module, while the 1.5 kW Integrative electric resistance kit can be installed on the 160 litre DHW storage tank of the TRIO V2 for DHW storage tank (code 3.024897). The system can be assembled by coupling the following required components:

- Installation casing (recessed or inside rooms):
SOLAR CONTAINER code 3.020166 or DOMUS CONTAINER code 3.022167.
- TRIO V2 code 3.027830, TRIO MONO V2 code 3.027831.
- Split heat pump:
MAGIS PRO 4 V2 code 3.030606;
MAGIS PRO 6 V2 code 3.030607;

MAGIS PRO 9 V2 code 3.030608.

- Kit for coupling to MAGIS PRO - code 3.026303 (inclusive of hydraulic fittings and for coolant gas, hydronic module support bracket).

Also, it is possible to couple the following optional additional components:

- 3 kW system integrative electric resistance kit code. 3.030991 to be inserted in the MAGIS PRO V2 hydronic module;
- 1.5 kW system integrative electric resistance kit for DHW storage tank code 3.024897;
- 15-Litre inertial storage kit code 3.026304;
- 50-Litre recessed inertial storage kit code 3.027709;
- DHW recirculation kit (does not include pump) code 3.026169, any clock/timer to activate the pump is to be provided separately;
- Antifreeze kit up to -15 °C code 3.017324 to protect the hydronic module.

The above kits are the main ones, for further options see dedicated section.

39.2 MAIN COMPONENTS SYSTEM PRO WITH ELECTRIC RESISTANCES

KEY:

- 1 - Storage tank draining cock / tap
- 2 - Solar probe (optional)
- 3 - Antifreeze thermostat
- 4 - 8 bar safety valve
- 5 - Storage tank flange
- 6 - Domestic hot water vessel shut-off cock
- 7 - Antifreeze kit connection box
- 8 - 8l domestic hot water expansion vessel
- 9 - Heat pump probe ACS
- 10 - One-way valve
- 11 - 1.5 kW DHW integrative electric resistance (optional)
- 12 - Heat pump probe ACS (to be moved in the presence of DHW electrical resistance)
- 13 - Sacrificial anode
- 14 - Storage tank / Cylinder
- 15 - 3 kW system integrative electric resistance (optional)
- 16 - Management electronics
- 17 - Indoor unit MAGIS PRO V2
- 18 - DHW circuit mixing valve
- 19 - Three-way valve of precedence
- 20 - Manifold draining valves
- 21 - Hydraulic manifold
- 22 - Mixing valve zone 1
- 23 - System flow probe
- 24 - Direct zone pump
- 25 - Safety thermostat (mixed) zone
- 26 - (Mixed) zone 1 flow probe
- 27 - Mixed zone pump / circulator
- 28 - Zone 1 flow temperature thermometer (mixed)
- 29 - Zone 2 flow temperature thermometer (direct)

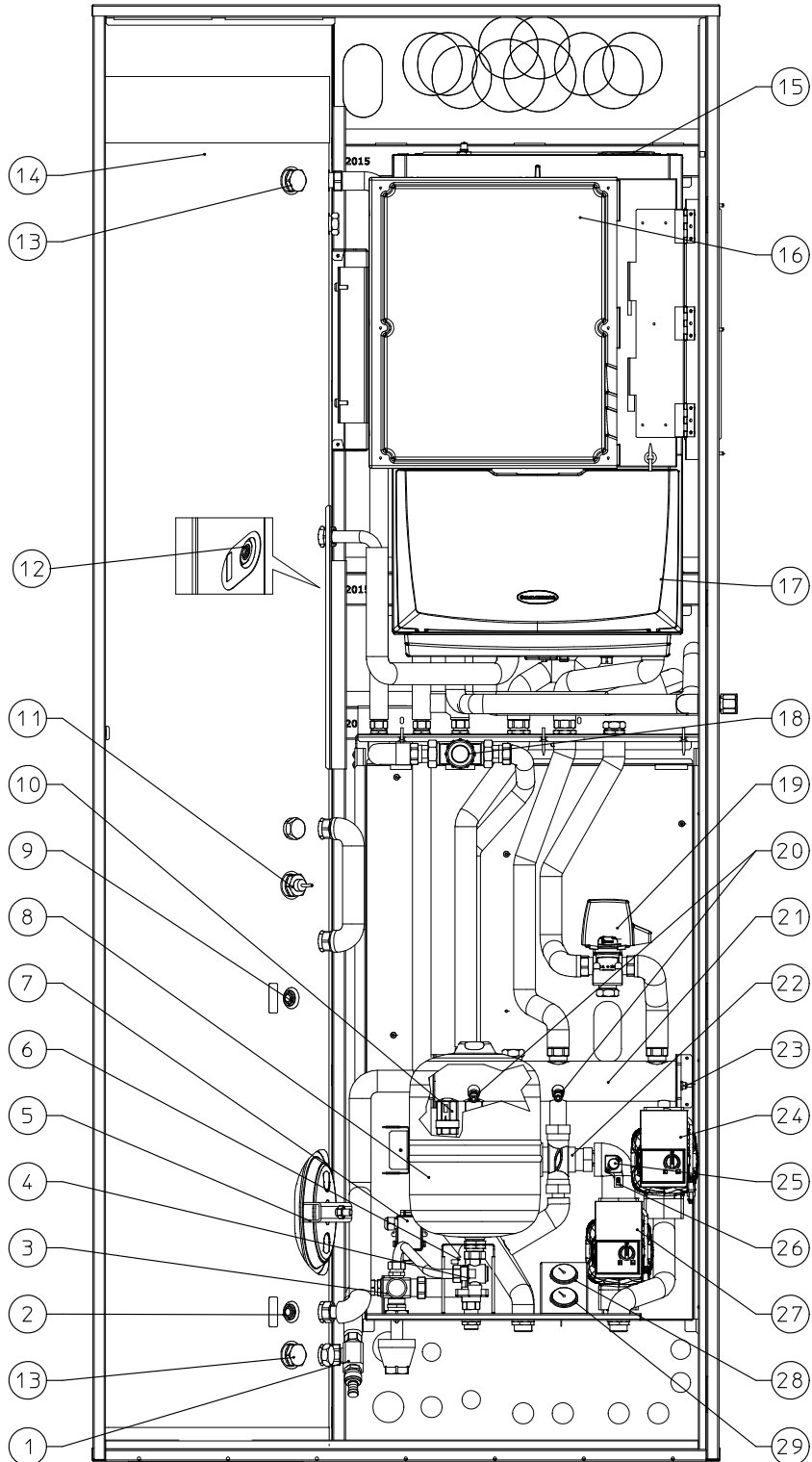

N.B.: In the presence of the DHW electrical resistance (11 optional) it is advisable, in order to improve the system, to move the probe (9) placing it as indicated in point (12).

MAGIS PRO V2

39.3 DIAGRAM SYSTEM TRIO SYSTEM PRO: SYSTEM WITH ONE CENTRAL HEATING ZONE WITH RADIANT PANELS + ONE COOLING AND CENTRAL HEATING ZONE WITH FAN COILS

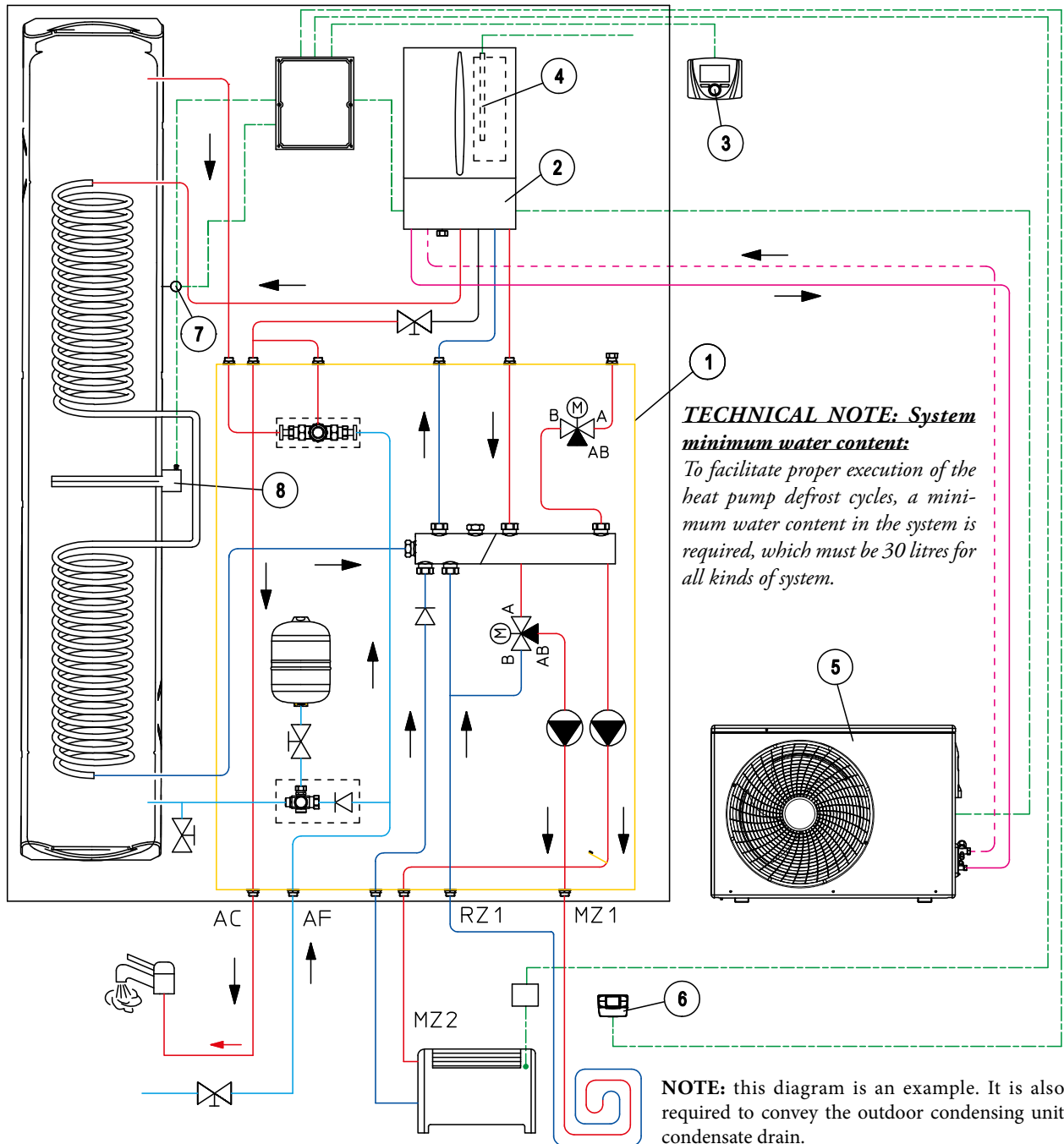

KEY:

- | | |
|---|---|
| <ul style="list-style-type: none"> 1 - System TRIO V2 composed of: <ul style="list-style-type: none"> • Double coil 160 litre storage tank • Hydronic group • P.C.B. • Remote panel 2 - MAGIS PRO V2 Indoor Unit | <ul style="list-style-type: none"> 3 - Remote Panel (standard with TRIO V2) 4 - Integrative electric resistance for heating system 5 - AUDAX PRO V2 Condensing unit 6 - CHRONO 7 7 - DHW probe (standard with TRIO V2) 8 - Integrative electric resistance for DHW storage tank |
|---|---|

39.4

TRIO SYSTEM PRO OPTIONAL

OPTIONAL components but necessary to complete the SYSTEM PRO	Code
TRIO V2	3.027830
TRIO MONO V2	3.027831
SOLAR CONTAINER	3.020166
DOMUS CONTAINER	3.022167
MAGIS PRO 4 V2	3.030606
MAGIS PRO 6 V2	3.030607
MAGIS PRO 9 V2	3.030608
Accessory kit for MAGIS PRO coupling (including hydraulic and coolant gas fittings, hydronic module support bracket and storage tank probe for MAGIS PRO)	3.026303
SYSTEM PRO OPTIONAL components	Code
3 kW integration electric resistance kit (to be inserted inside the MAGIC PRO V2 hydronic module, 230 Vac power supply)	3.030991
1,5 kW sanitary electric resistance	3.024897
Antifreeze protection kit -15 °C (for hydronic module protection)	3.017324
DHW recirculation kit ⁽¹⁾ - (pump NOT included)	3.026169
Aesthetic upper cover for DOMUS CONTAINER	3.027175
Buffer tank 15 litres	3.026304
External probe - if AUDAX PRO V2 is installed under unfavourable conditions - (device class II* or VI or VII)	3.015266
Zone Remote panel - (device class V* or VI)	3.030863
Zone Remote control kit - it cannot be combined with TRIO MONO V2 - (device class V or VI*)	3.023364
Low temperature safety kit	3.019229
OPTIONAL components available for all systems TRIO	Code
CRONO 7 - (device class IV* or VII)	3.021622
CRONO 7 WIRELESS (device class IV* or VII)	3.021624
Room hygrostat	3.023302
Temperature/humidity active sensor kit - it cannot be combined with TRIO MONO V2 (device class V or VI*)	3.021524
Bottom connection unit kit for lower connection	3.020575
Lateral connection unit kit for side connection	3.020574
Rear connection unit kit for rear connection	3.020630
Anti scale kit ⁽¹⁾	3.020628
Three-way diverter valve kit to be used as diverter valve for heating/cooling switching	3.020632
Dehumidifier kit - only for recessed installation combined with dehumidifier frame kit and grid kit	3.021529
Dehumidifier frame kit	3.022146
Dehumidifier grid kit	3.022147
Recessed buffer tank 50 litres	3.027709
Wall installation brackets kit for outdoor condensing unit	3.022154
Condensate antifreeze heating cable kit (for outdoor condensing unit)	3.027385
DOMINUS Interface kit (for remote control via App)	3.026273
Solar kit **	3.024719

* Device class (REF. Communication of the European Commission 2014/C 207/02) with factory settings.

** In case of application with solar heating, as well as Kit code 3.024719, the solar heating components on the list are available. We recommend using flat solar manifolds.

(1) The DHW recirculation Kit and the polyphosphate dispenser kit CANNOT coexist together within the SOLAR CONTAINER and/or DOMUS CONTAINER.

MAGIS PRO V2

APPENDIX C): BASIC MAGIS PRO WITH MAGIS PRO V2

40 BASIC MAGIS PRO WITH MAGIS PRO V2 IN SOLAR / DOMUS CONTAINER

Recessed or technical cabinet solution, ideal for high energy class and small apartments, it allows the recovery of living space thanks to the retractable installation.

The complete system consists of separate units that can be purchased separately and installed at different times:

- SOLAR CONTAINER (Recess frame);
- DOMUS CONTAINER (technical cabinet);
- MAGIS PRO V2 in its various power;
- BASIC MAGIS PRO Pack;
- Hydraulic connections kit for vertical, horizontal or rear outlet (optional);
- System electrical resistance kit (optional);
- DHW electrical resistance kit (optional);
- Solar system coupling kit (optional).



40.1

BASIC MAGIS PRO MAIN COMPONENTS

KEY:

- 1 - Storage tank draining cock / tap
- 2 - Solar probe (optional)
- 3 - 8 bar safety valve
- 4 - DHW (Domestic hot water) vessel interception cock
- 5 - Storage tank flange
- 6 - Antifreeze thermostat
- 7 - Antifreeze kit connection box
- 8 - 8 l domestic hot water expansion vessel
- 9 - 1.5 kW Domestic hot water integrative electric resistance (optional)
- 10 - DHW probe
- 11 - Sacrificial anode
- 12 - Storage tank / Cylinder
- 13 - 3 kW system integrative electric resistance (optional)
- 14 - MAGIS PRO V2 Indoor Unit
- 15 - Circuit mixing valve domestic hot water
- 16 - Zone 2 flow temperature thermometer (high temperature)

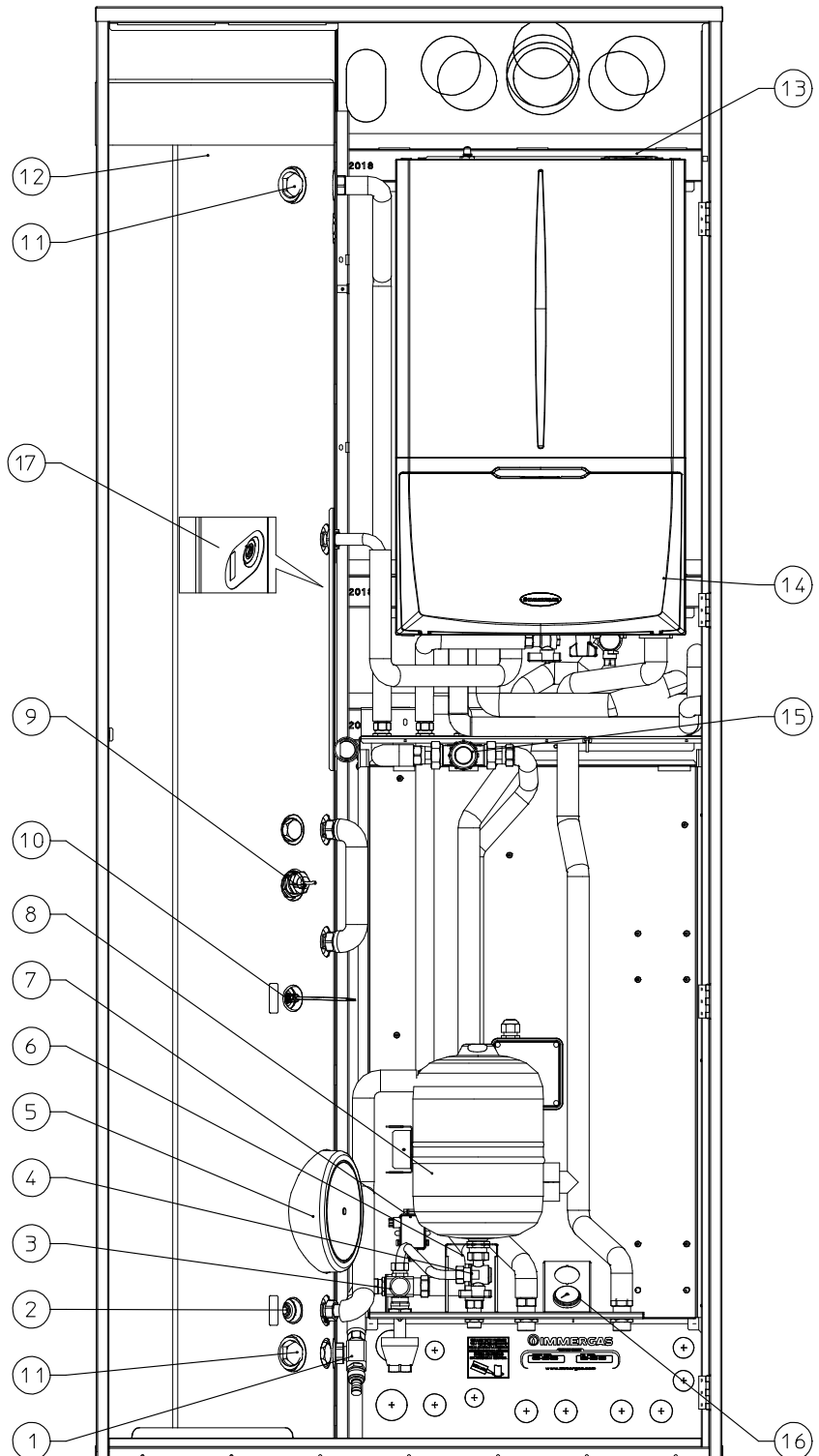

MAGIS PRO V2

40.2 RECESS BASIC MAGIS PRO SYSTEM DIAGRAM: SYSTEMS WITH RADIANT PANELS AND COOLING WITH FAN COILS

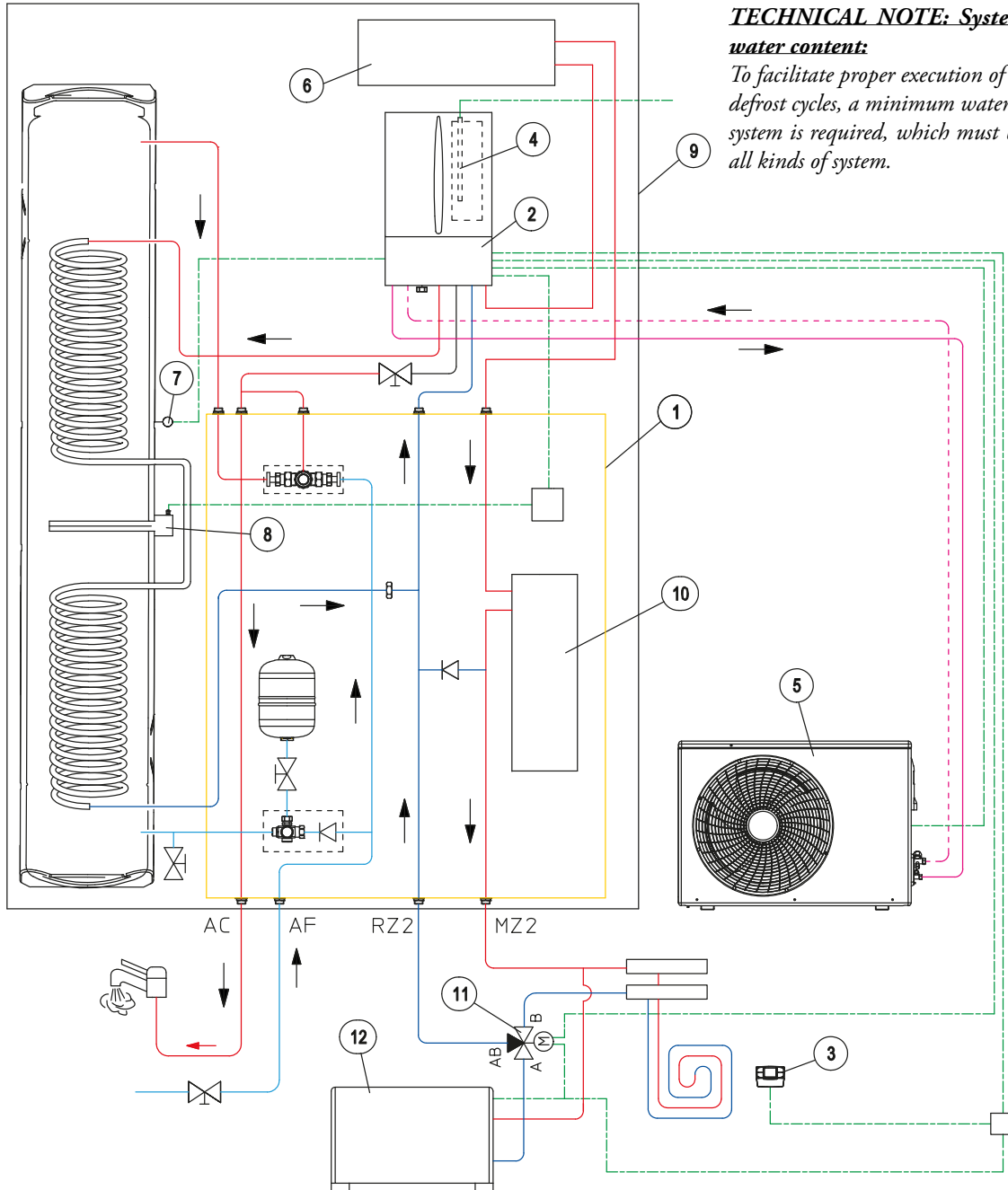

TECHNICAL NOTE: System minimum water content:

To facilitate proper execution of the heat pump defrost cycles, a minimum water content in the system is required, which must be 30 litres for all kinds of system.

NOTE: this diagram is an example. It is also required to convey the outdoor condensing unit condensate drain.

KEY:

- | | |
|--|--|
| 1 - BASIC MAGIS PRO Pack | 7 - DHW probe |
| 2 - MAGIS PRO V2 Indoor Unit | 8 - Integrative electric resistance for DHW storage tank |
| 3 - CHRONO 7 | 9 - SOLAR CONTAINER |
| 4 - Integrative electric resistance for heating system | 10 - 15-Litre inertial storage tank code 3.029928 (it only can be inserted in SOLAR CONTAINER) |
| 5 - AUDAX PRO V2 Condensing unit | 11 - Summer/winter deviator valve |
| 6 - 15-Litre inertial storage kit code. 3.026304 | 12 - HYDRO FS fan coil |

40.3

OPTIONAL BASIC MAGIS PRO

OPTIONAL components but necessary to make the BASIC MAGIS PRO system	Code
SOLAR CONTAINER (Recess frame)	3.020166
DOMUS CONTAINER (technical cabinet)	3.022167
BASIC MAGIS PRO Pack	3.029721
MAGIS PRO 4 V2	3.030606
MAGIS PRO 6 V2	3.030607
MAGIS PRO 9 V2	3.030608
TEMPERATURE CONTROL OPTIONALS available for the BASIC MAGIS PRO system	Code
Zone Remote panel - (device class V* or VI)	3.030863
Temperature and humidity sensor kit ModBus - (device class V or VI*) - to make temperature requests, it is necessary to couple a chrono-thermostat code 3.021622 or 3.021624	3.030992
CRONO 7 (Digital weekly chrono-thermostat) - (device class IV* or VII)	3.021622
CRONO 7 WIRELESS - (device class IV* or VII)	3.021624
External probe - if AUDAX PRO V2 is installed under unfavourable conditions - (device class II* or VI or VII)	3.015266
Room hygrostat - (operates on the Dehumidifier according to the humidity detected in the room and according to what is set on the device)	3.023302
OTHER OPTIONALS available for the BASIC MAGIS PRO system	Code
3 kW integration electric resistance kit (to be inserted inside the MAGIC PRO V2 hydronic module, 230 Vac power supply)	3.030991
1,5 kW sanitary electric resistance	3.024897
Antifreeze protection kit -15 °C (for hydronic module protection)	3.017324
Bottom connection unit kit for lower connection	3.020575
Lateral connection unit kit for side connection	3.020574
Rear connection unit kit for rear connection	3.020630
Three-way diverter valve kit to be used as diverter valve for heating/cooling switching	3.020632
Configurable relay board kit (to manage ACS recirculation)	3.015350
2 relay board kit for MAGIS PRO V2 coupling (for dehumidifier control)	3.026302
Dehumidifier kit - for recessed installation only	3.021529
Dehumidifier frame kit	3.022146
Dehumidifier grid kit	3.022147
Condensate antifreeze heating cable kit (for outdoor condensing unit)	3.027385
Wall installation brackets kit for outdoor condensing unit	3.022154
Buffer tank 15 litres (it can be inserted in SOLAR CONTAINER and DOMUS CONTAINER)	3.026304
Buffer tank 15 litres for BASIC MAGIS PRO (it ONLY can be inserted in SOLAR CONTAINER)	3.029928
Recessed buffer tank 50 litres	3.027709
Aesthetic upper cover for DOMUS CONTAINER	3.027175
DHW recirculation kit ⁽¹⁾ - (pump NOT included)	3.026169
Anti scale kit ⁽¹⁾	3.020628
Low temperature safety kit	3.019229
DOMINUS Interface kit (for remote control via App)	3.026273
Solar kit **	3.024719

* Device class (REF. Communication of the European Commission 2014/C 207/02) with factory settings.

** In case of application with solar heating, as well as Kit code 3.024719, the solar heating components on the list are available. We recommend using flat solar manifolds.

(1) The DHW recirculation Kit and the polyphosphate dispenser kit CANNOT coexist together within the SOLAR CONTAINER and/or DOMUS CONTAINER.

MAGIS PRO V2

APPENDIX B): SUPER TRIO WITH MAGIS PRO V2

41

SUPER TRIO WITH MAGIS PRO V2 IN CONTAINER FOR SUPER TRIO

SUPER TRIO is the solution for new buildings, designed to build hybrid systems or with heat pump only in large apartments and villas, to easily meet the obligations on the use of renewable energy in new systems and major renovations; ideal in those situations where you have to cope with the need for a lot of hot water (e.g. whirlpool baths) or where you expect more simultaneous withdrawals, thanks to a DHW storage of 250 litres.

The system can be built with extreme flexibility and with great ease of installation in recessed or technical cabinet, the SUPER TRIO hydronic unit in fact integrates into the structures of the building and saves living space thanks to the

specific recessed CONTAINER.

The complete system consists of separate units that can be purchased separately and installed at different times:

- SOLAR CONTAINER for SUPER TRIO (Recessed frame);
- DOMUS CONTAINER for SUPER TRIO (Technical cabinet);
- MAGIS PRO V2 in its various power;
- SUPER TRIO pack;
- 2nd additional mixed zone kit (optional);
- System electrical resistance kit (optional);
- DHW electrical resistance kit (optional);
- Solar system coupling kit (optional).

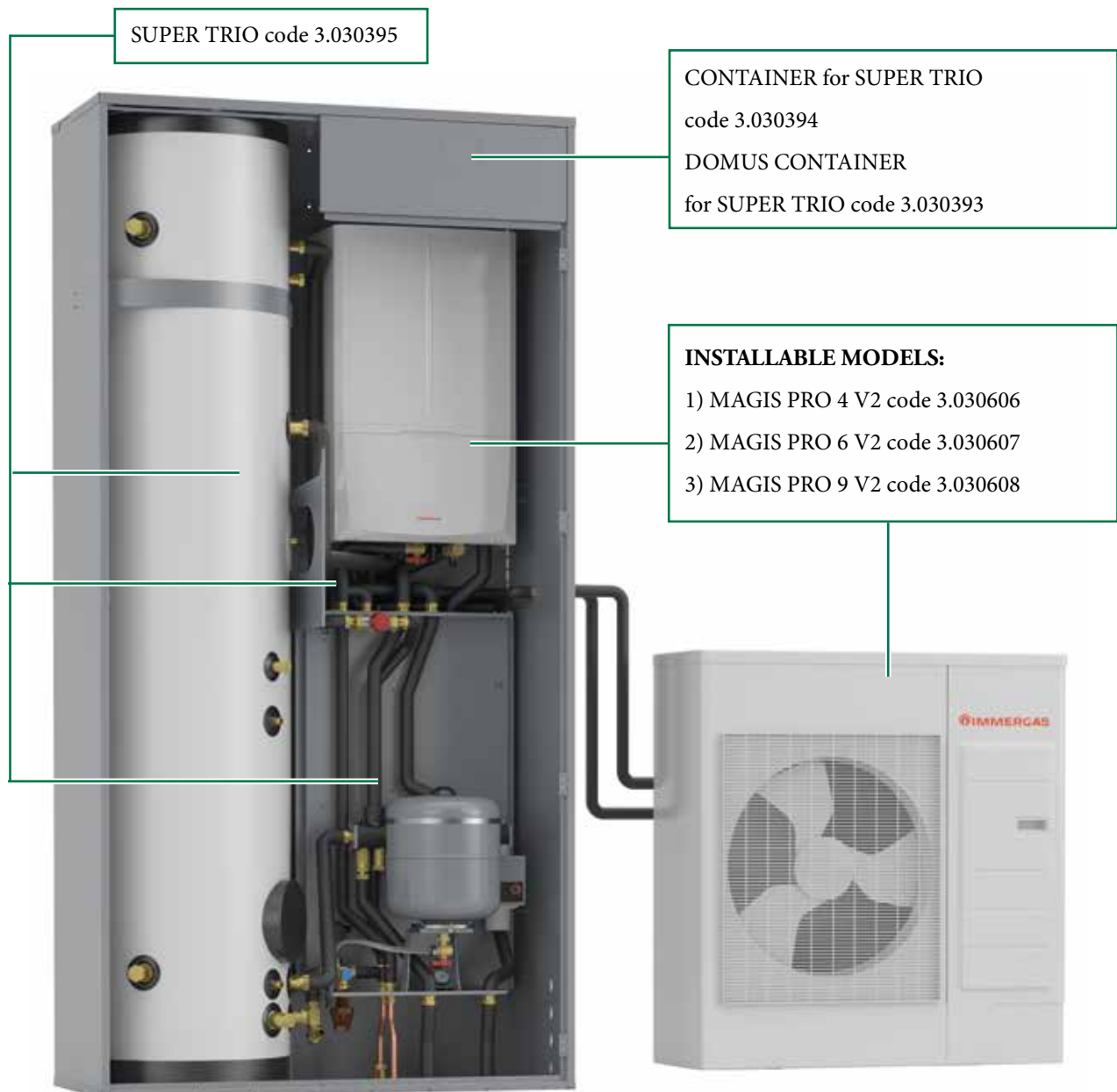

41.1

MAIN COMPONENTS SUPER TRIO WITH MAGIS PRO V2

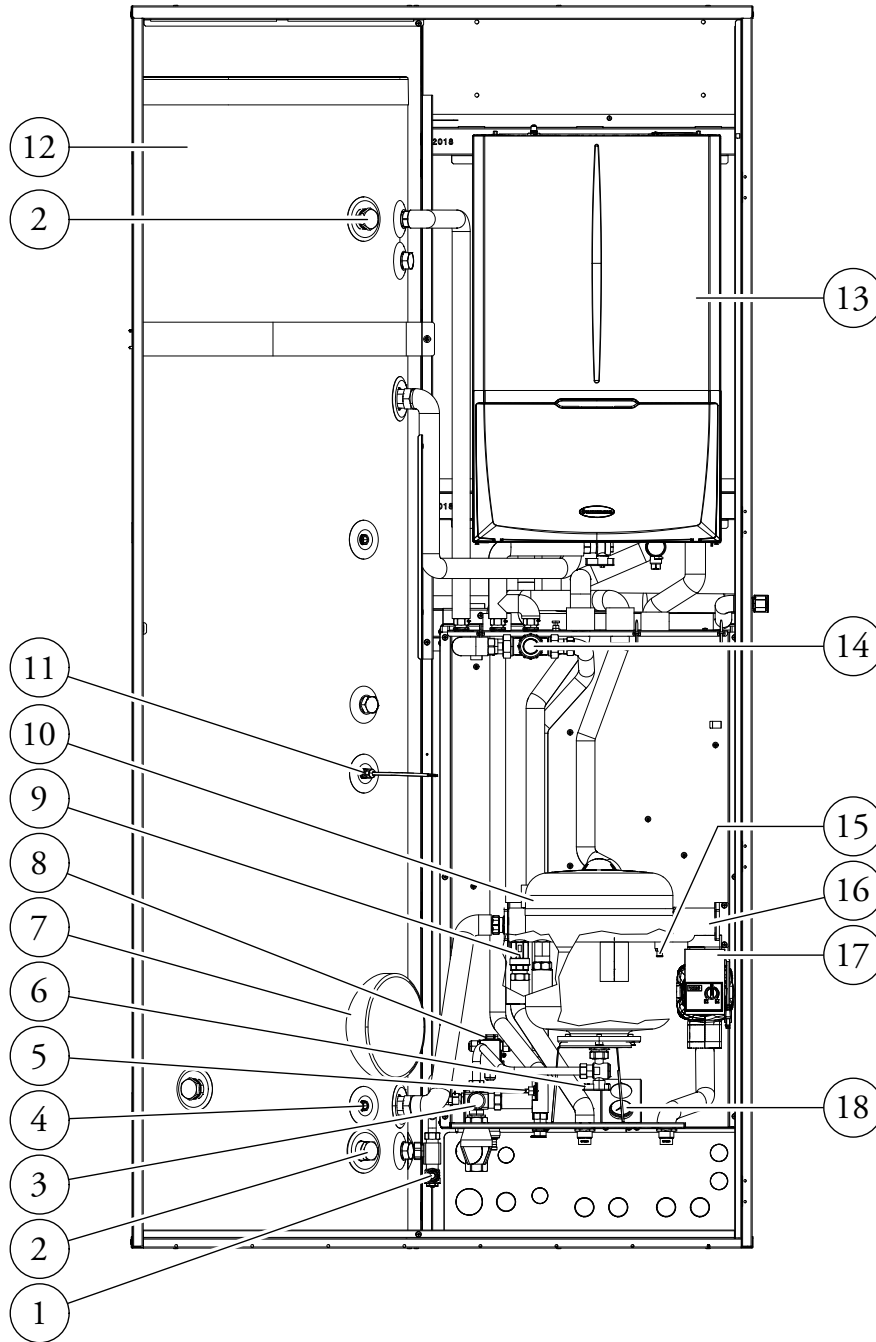

KEY:

- | | |
|---|--|
| 1 - Storage tank draining cock / tap | 10 - DHW (Domestic hot water) 16l expansion vessel |
| 2 - Sacrificial anodes | 11 - DHW probe |
| 3 - 8 bar safety valve | 12 - Storage tank / Cylinder |
| 4 - Solar probe (optional) | 13 - MAGIS PRO V2 Indoor Unit |
| 5 - Antifreeze thermostat | 14 - DHW circuit mixing valve |
| 6 - Domestic hot water vessel shut-off cock | 15 - Manifold draining valves |
| 7 - Storage tank flange | 16 - Hydraulic manifold |
| 8 - Antifreeze kit connection box | 17 - Direct zone pump |
| 9 - One-way valve | 18 - Zone 1 flow temperature thermometer (direct) |

MAGIS PRO V2

41.2 SUPER TRIO WITH MAGIS PRO V2 SYSTEM DIAGRAM: SYSTEMS WITH A RADIANT PANEL ZONE

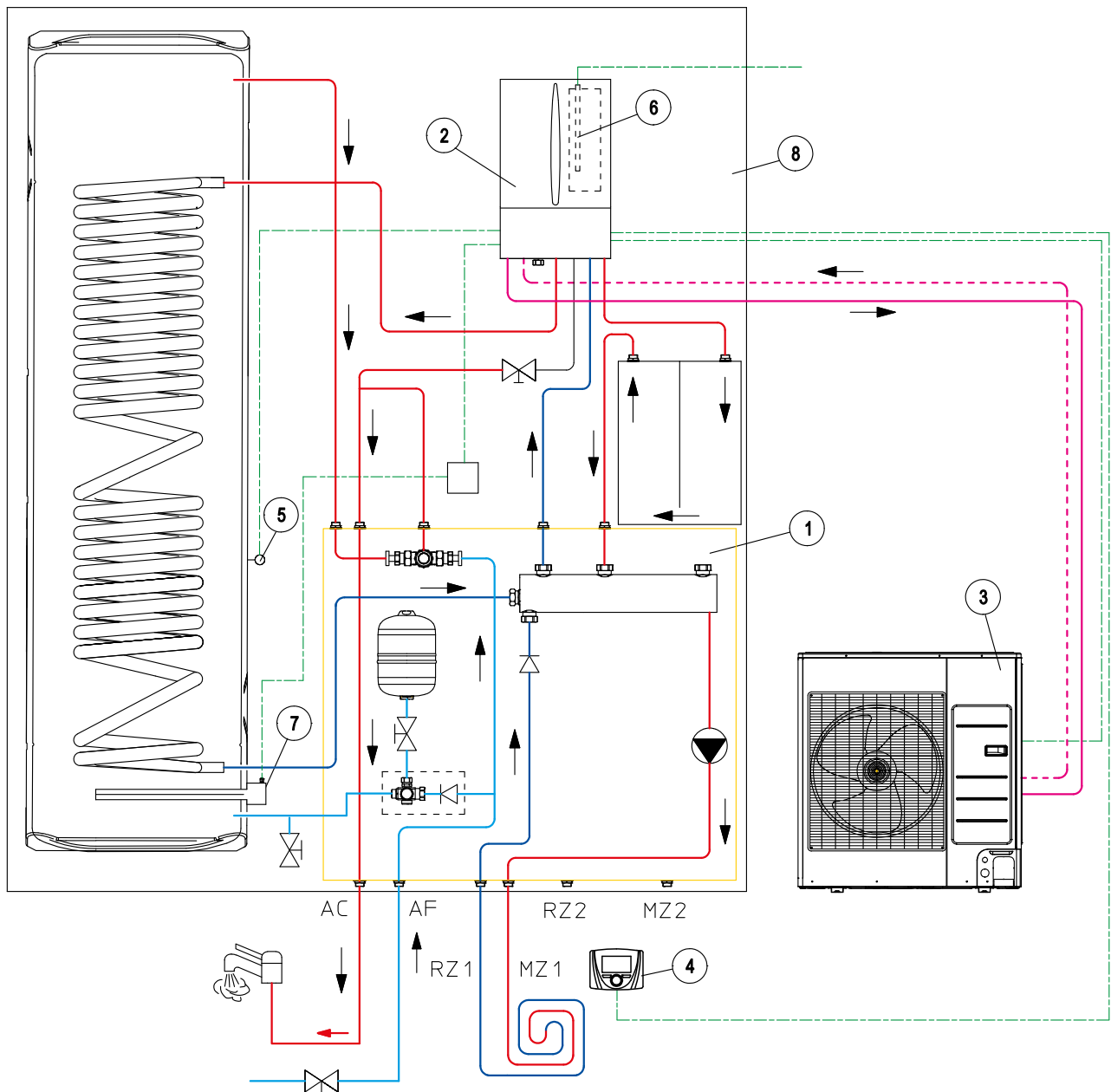

NOTE: this diagram is an example. It is also required to convey the outdoor condensing unit condensate drain.

KEY:

- | | |
|--|--|
| <p>1 - SUPER TRIO system consisting of:</p> <ul style="list-style-type: none"> • 250-Litre storage tank • Hydronic unit with direct pump • DHW vessel • 30-Litre inertial storage tank <p>2 - MAGIS PRO V2 Indoor Unit</p> | <p>3 - AUDAX PRO 9 V2 Condensing unit</p> <p>4 - Remote zone control</p> <p>5 - DHW probe</p> <p>6 - System resistance</p> <p>7 - ACS resistance</p> <p>8 - CONTAINER for SUPER TRIO</p> |
|--|--|

41.3

SUPER TRIO SYSTEM OPTIONAL

OPTIONAL components but necessary to complete the SUPER TRIO SYSTEM	Code
SUPER TRIO	3.030395
CONTAINER for SUPER TRIO	3.030394
DOMUS CONTAINER for SUPER TRIO	3.030393
Aesthetic upper cover for DOMUS CONTAINER for SUPER TRIO	3.030484
MAGIS PRO 4 V2	3.030606
MAGIS PRO 6 V2	3.030607
MAGIS PRO 9 V2	3.030608
Exclusive SUPER TRIO SYSTEM OPTIONAL components with MAGIS PRO V2	Code
Zone Remote panel - (device class V* or VI)	3.030863
Temperature and humidity sensor kit ModBus - (device class V or VI*) - to make temperature requests, it is necessary to couple a chrono-thermostat code 3.021622 or 3.021624	3.030992
3 kW integration electric resistance kit (to be inserted inside the MAGIC PRO V2 hydronic module, 230 Vac power supply)	3.030991
1,5 kW sanitary electric resistance	3.029927
CRONO 7 (Digital weekly chrono-thermostat) - (device class IV* or VII)	3.021622
CRONO 7 WIRELESS - (device class IV* or VII)	3.021624
External probe - if AUDAX PRO V2 is installed under unfavourable conditions - (device class II* or VI or VII)	3.015266
Room hygrostat - (operates on the Dehumidifier according to the humidity detected in the room and according to what is set on the device)	3.023302
Additional mixed 2nd zone kit	3.027865
Antifreeze protection kit -15 °C (for hydronic module protection)	3.017324
Bottom connection unit kit for lower connection	3.020575
Lateral connection unit kit for side connection	3.020574
Rear connection unit kit for rear connection	3.020630
Three-way diverter valve kit to be used as diverter valve for heating/cooling switching	3.020632
Configurable relay board kit	3.015350
2 relay board kit for MAGIS PRO V2 coupling (for dehumidifier control)	3.026302
Dehumidifier kit - for recessed installation only	3.021529
Dehumidifier frame kit	3.022146
Dehumidifier grid kit	3.022147
Condensate antifreeze heating cable kit (for outdoor condensing unit)	3.027385
Wall installation brackets kit for outdoor condensing unit	3.022154
DHW recirculation kit ⁽¹⁾ - (pump NOT included)	3.030483
Anti scale kit ⁽¹⁾	3.020628
Low temperature safety kit	3.019229
DOMINUS Interface kit (for remote control via App)	3.026273
Solar kit: **	
consisting of a single solar circulation unit, solar control unit, 16-plate heat exchanger, connection tubes, 18-litre solar expansion vessel and temperature sensors (for storage tank and solar collector)	3.030482

* Device class (REF. Communication of the European Commission 2014/C 207/02) with factory settings.

** In case of application with solar heating, as well as Kit code 3.030482, the solar heating components on the list are available. The use of 2 CP4 M flat solar collectors or 1 CP4 XL flat solar collector is recommended.

(1) The DHW recirculation Kit and the polyphosphate dispenser kit CANNOT coexist together within the CONTAINER and/or DOMUS CONTAINER for SUPER TRIO.